

FYH®

SPHERICAL ROLLER BEARING UNITS

Premium

Supra

Eco

EasyRoll

ABEG
Advanced Bearing Expert Group



Introducing FYH Spherical Roller Bearing Units

More than sixty-five years of experience and innovation in the field of mounted ball bearing units has lead to the development of mounted spherical roller units that cater to a wide range of applications and industries. Bearing and housing production are accomplished entirely by FYH while utilizing only the highest quality materials available. Through meticulous design enhancements and careful material selection this heavy duty mounted roller series attains the designation of "EXTRA TOUGH".

EXTRA TOUGH



The patented Z Lock is the first ever tapered bore locking collar system. Just tighten the cap screws properly and the specialized tapered bore collar provides extreme holding power on the shaft without causing any damage. This is a true 360 degree locking mechanism. Disassembly is easily accomplished with two threaded holes in the collar for standard withdrawal dismounting.

Lubrication

FYH Roller Grease is a calcium sulfonate complex thickened lubricating grease formulated in 100% synthetic hydrocarbon base oil.

FYH Roller Grease has excellent low temperature and high temperature performance, and it provides excellent extreme pressure and anti-wear protection. FYH Roller Grease also provides excellent corrosion protection and water wash-out resistance. Grease temperature range: -40 to 340°F (-40 to 170°C)

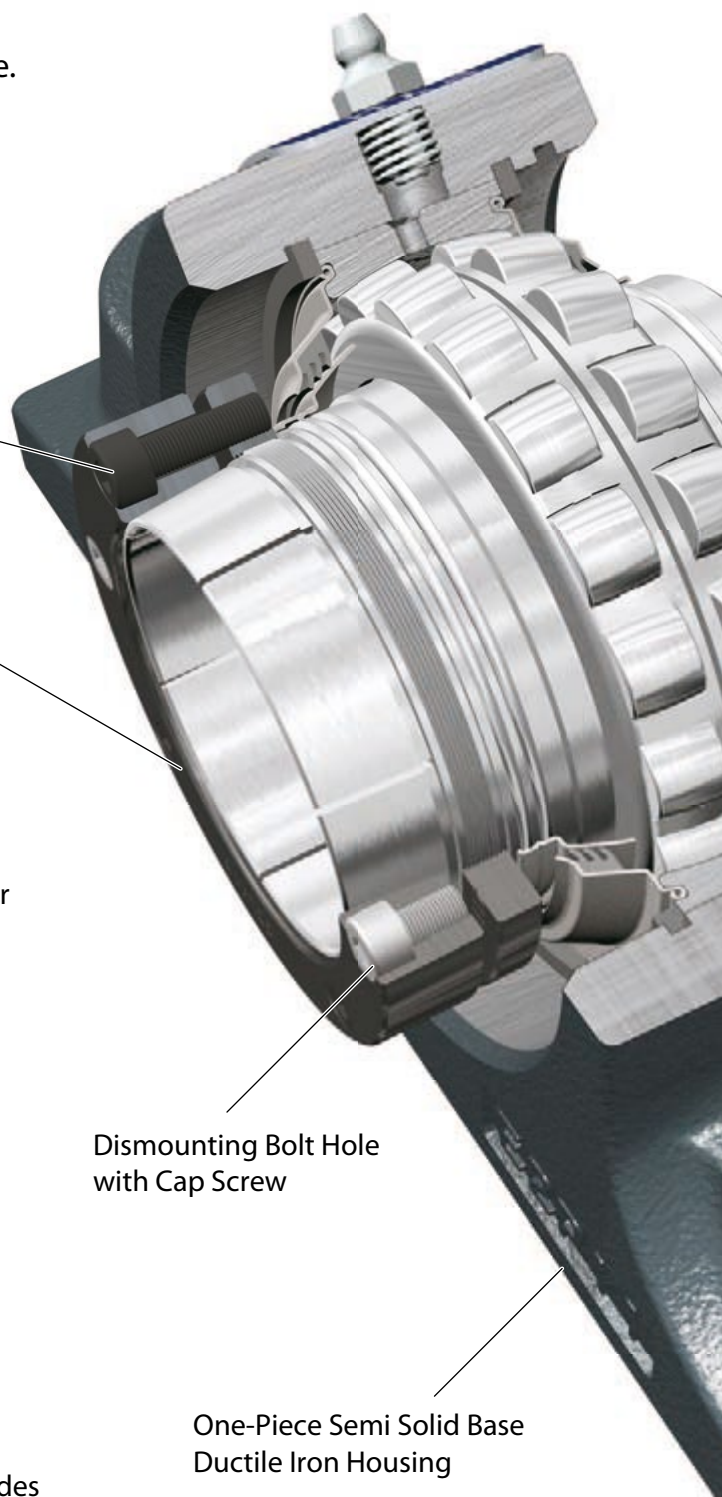

Locking Cap Screw

Tapered Bore Locking Collar

Dismounting Bolt Hole with Cap Screw

One-Piece Semi Solid Base Ductile Iron Housing

Triple Lip Seal

$\pm 2^\circ$ Self Aligning capability

The triple lip seal maintains positive contact with a special sealing ring at virtually any angle of shaft mis-alignment. Our new patented sealing design protects the bearing against a variety of wet and dry contaminants and dramatically improves bearing life. The ability to accommodate shaft expansion is also available.

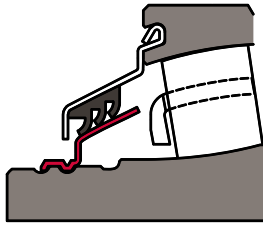

Triple Lip Seal

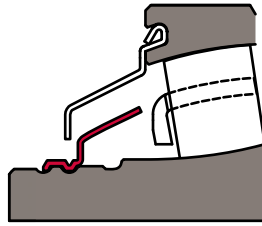

Labyrinth non-contact Seal for higher speeds & high temperature applications

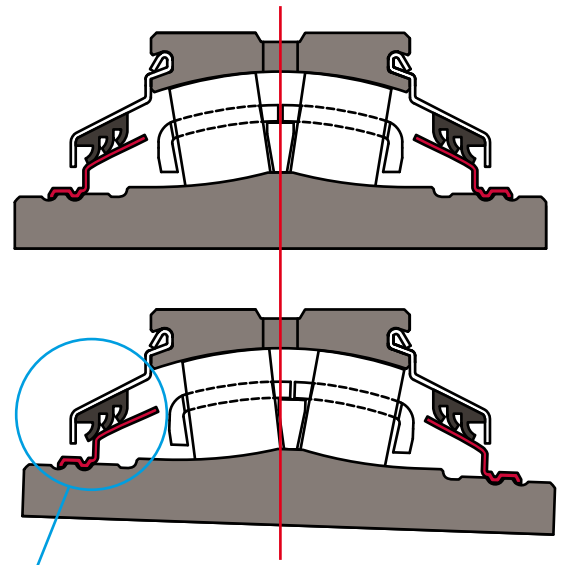

Positive seal contact is maintained during mis-alignment at any angle.

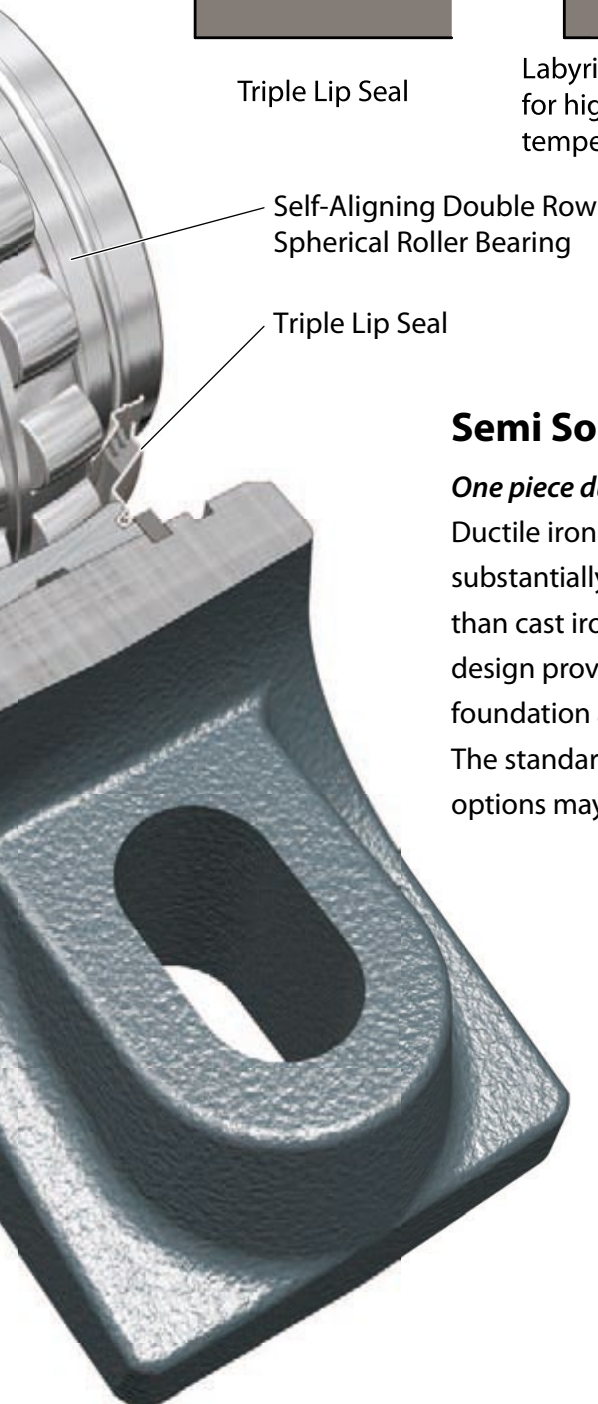

Self-Aligning Double Row Spherical Roller Bearing

Triple Lip Seal

Semi Solid Base

One piece ductile iron housings

Ductile iron housings offer substantially better fracture resistance than cast iron, and the semi-solid base design provides an excellent mounting foundation and superior rigidity over competitive offerings.

The standard housing material from FYH is ductile iron, and additional material options may also be available.



Convertible from non-expansion to expansion

By simply moving a snap ring on the back of the unit the bearing can easily be converted from non-expansion to expansion or vice versa.

This procedure can be easily performed in the field even after the unit has been mounted.

FYH patented Z LOCK and set screw lock spherical roller bearing units now have SN style housings for the replacement of SN plumber blocks.

COMPARISON OF FYH SN UNITS AND SN PLUMMER BLOCK UNITS

SAME CENTER HEIGHT
AND MOUNTING PITCH

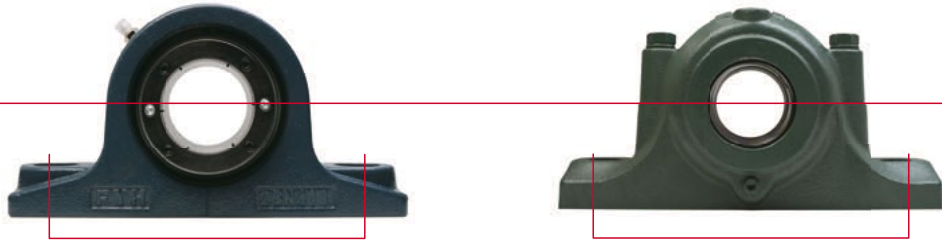

	FYH SN UNITS	SN PLUMMER BLOCK UNITS
HOUSING	ONE PIECE DUCTILE IRON	SPLIT GRAY CAST IRON
LOCKING	Z LOCK OR SET SCREW	ADAPTER SLEEVE
SEAL	ORIGINAL ALIGNED TRIPLE LIP ON INNER RING	SINGLE LIP SEAL ON SHAFT
SELF ALIGNING CAPABILITY	±2°	±1°
LUBRICATION	CALCIUM SULFONATE SYNTHETIC GREASE	NONE
INSTALLATION	TIGHTENING 4 CAP SCREWS FOR Z LOCK TIGHTENING 2 SET SCREWS FOR SET SCREW LOCK LESS THAN 10 MINUTES	ASSEMBLY HOUSING MANUAL CLEARANCE ADJUSTMENT OF INSERT WITH FEELER GAUGES FILLING WITH THE LUBRICANT MORE THAN 45 MINUTES

Contamination is the single biggest problem that bearings face in applications such as aggregate, mining, forestry, pulp and paper and steel mills. Split plumber block units have single lip rubber seals that contact and wear on the shafting. **FYH’s original triple lip seals contact on the inner ring and can handle ±2 degrees of shaft misalignment, plumber block seals are not designed for this amount of misalignment.** Adapter sleeves used in a split plumber blocks require time and skill to install correctly, incorrect installation can allow them to be too tight or too loose. FYH’s true concentric Z Lock can be installed much faster and easier than adaptor sleeve locks. **The installation of Z Lock bearings should be able to be completed in less than ten minutes and saves cost in both time and manpower.**

Nomenclature

The nomenclature of a FYH Spherical Roller Unit is comprised of the roller bearing unit model code which is made up using the bearing model code and the housing model code. This in combination with the diameter series code, bore diameter code, accessory code and any special

code for individual applications determines the FYH Spherical Roller Units part number.



http://www.fyhbearings.com/html/nomenclature_r.html

FYH Spherical Roller Bearing Units

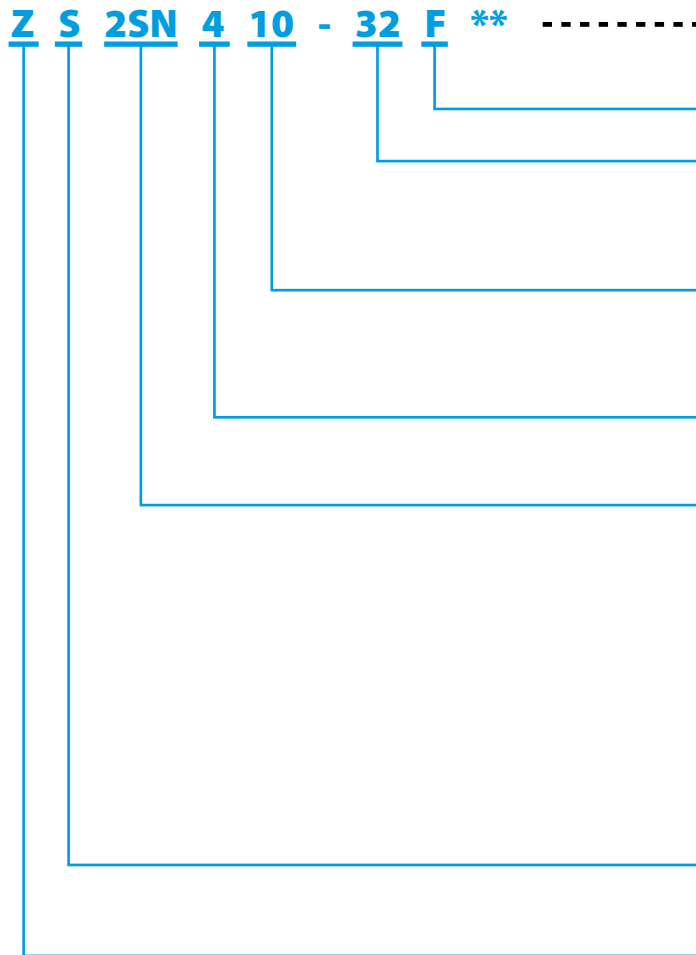

Bearing No.	_____	ZS410-32
Housing No.	_____	2SN10

EXPANSION Type

Bore Size (inch)

Number of $\frac{1}{16}$ " of Inches
(ex. 32 = 2")

Bore Size (base)

Metric type $\times 5$ mm of Number
(ex. 10 = 50 mm)

Series code

4 Spherical Roller

Housing model code

2SN 2 - Bolt Base Type SN Pillow Block

2P 2 - Bolt Base Pillow Block

4P 4 - Bolt Base Pillow Block

4F 4 - Bolt Flange

4FC Flange Cartridge

T Take - Up

E2P 2 - Bolt Base Pillow Block : TYPE E (inch)

E4F 4 - Bolt Flange : TYPE E (inch)

INSERT-2 model code

S Spherical Roller

INSERT-1 Locking Type code

Z Z Lock Concentric Locking System

ZD Z Lock Concentric Locking System
(Both side)

X Concentric set screw lock (One side)

XD Concentric set screw lock (Both side)

Engineering Information of FYH Spherical Roller Bearings

Spherical Roller Bearing Life Calculations

The relationship between the basic rating life, the basic dynamic load rating, and the dynamic equivalent load of the spherical roller bearing is indicated in Formula A. If the spherical roller bearing unit is being used at a fixed rotating speed, the life is indicated as time. This is shown in Formula B.

$$A. L_{10} = \left(\frac{C_r}{P_r} \right)^{\frac{10}{3}}$$

$$B. L_{10h} = \frac{10^6 L_{10}}{60n} = \frac{10^6}{60n} \left(\frac{C_r}{P_r} \right)^{\frac{10}{3}}$$

L_{10} : Basic Rating Life 10^6 rotations

L_{10h} : Rated Life (hr)

C_r : Basic Dynamic Load Rating (kN)

P_r : Dynamic equivalent Load (kN)

n : Speed (min^{-1})

FYH patented Z LOCK and set screw lock spherical roller bearing units now have SN style housings for the replacement of SN plumber blocks.

COMPARISON OF FYH SN UNITS AND SN PLUMMER BLOCK UNITS

SAME CENTER HEIGHT
AND MOUNTING PITCH

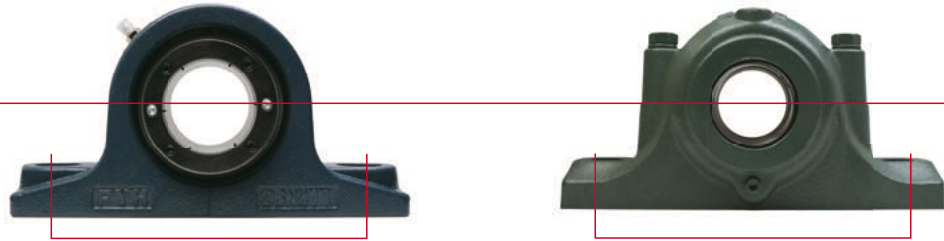

	FYH SN UNITS	SN PLUMMER BLOCK UNITS
HOUSING	ONE PIECE DUCTILE IRON	SPLIT GRAY CAST IRON
LOCKING	Z LOCK OR SET SCREW	ADAPTER SLEEVE
SEAL	ORIGINAL ALIGNED TRIPLE LIP ON INNER RING	SINGLE LIP SEAL ON SHAFT
SELF ALIGNING CAPABILITY	$\pm 2^\circ$	$\pm 1^\circ$
LUBRICATION	CALCIUM SULFONATE SYNTHETIC GREASE	NONE
INSTALLATION	TIGHTENING 4 CAP SCREWS FOR Z LOCK TIGHTENING 2 SET SCREWS FOR SET SCREW LOCK LESS THAN 10 MINUTES	ASSEMBLY HOUSING MANUAL CLEARANCE ADJUSTMENT OF INSERT WITH FEELER GAUGES FILLING WITH THE LUBRICANT MORE THAN 45 MINUTES

Contamination is the single biggest problem that bearings face in applications such as aggregate, mining, forestry, pulp and paper and steel mills. Split plumber block units have single lip rubber seals that contact and wear on the shafting. **FYH's original triple lip seals contact on the inner ring and can handle ± 2 degrees of shaft misalignment, plumber block seals are not designed for this amount of misalignment.** Adapter sleeves used in a split plumber blocks require time and skill to install correctly, incorrect installation can allow them to be too tight or too loose. FYH's true concentric Z Lock can be installed much faster and easier than adaptor sleeve locks. **The installation of Z Lock bearings should be able to be completed in less than ten minutes and saves cost in both time and manpower.**

Nomenclature

The nomenclature of a FYH Spherical Roller Unit is comprised of the roller bearing unit model code which is made up using the bearing model code and the housing model code. This in combination with the diameter series code, bore diameter code, accessory code and any special

code for individual applications determines the FYH Spherical Roller Units part number.



http://www.fyhbearings.com/html/nomenclature_r.html

FYH Spherical Roller Bearing Units

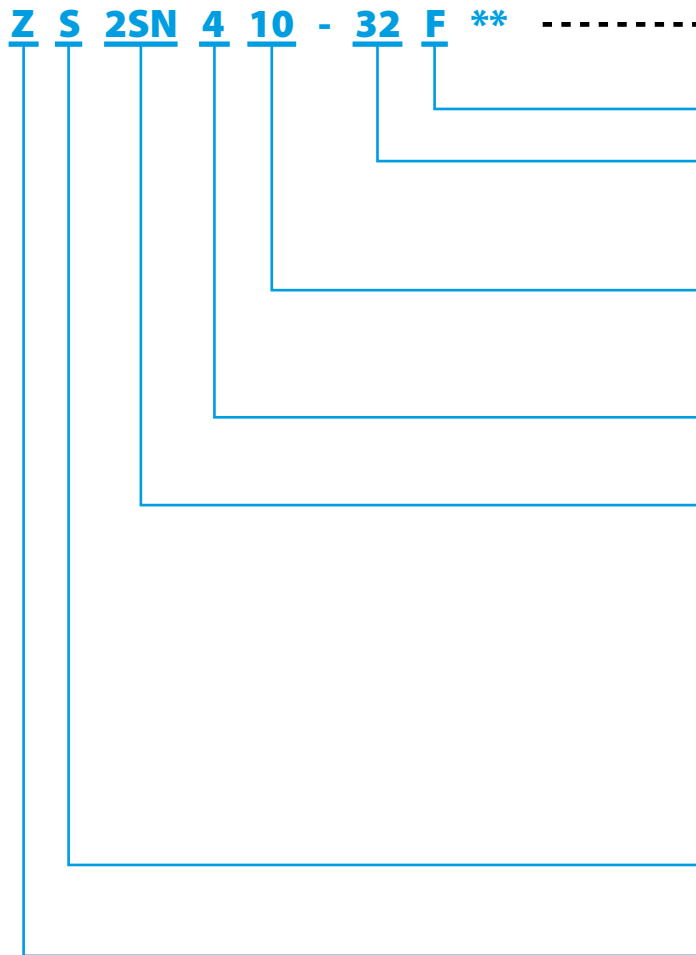

Bearing No.	_____	ZS410-32
Housing No.	_____	2SN10

EXPANSION Type

Bore Size (inch)

Number of $\frac{1}{16}$ " of Inches
(ex. 32 = 2")

Bore Size (base)

Metric type $\times 5$ mm of Number
(ex. 10 = 50 mm)

Series code

4 Spherical Roller

Housing model code

2SN 2 - Bolt Base Type SN Pillow Block

2P 2 - Bolt Base Pillow Block

4P 4 - Bolt Base Pillow Block

4F 4 - Bolt Flange

4FC Flange Cartridge

T Take - Up

E2P 2 - Bolt Base Pillow Block : TYPE E (inch)

E4F 4 - Bolt Flange : TYPE E (inch)

INSERT-2 model code

S Spherical Roller

INSERT-1 Locking Type code

Z Z Lock Concentric Locking System

ZD Z Lock Concentric Locking System
(Both side)

X Concentric set screw lock (One side)

XD Concentric set screw lock (Both side)

Engineering Information of FYH Spherical Roller Bearings

Spherical Roller Bearing Life Calculations

The relationship between the basic rating life, the basic dynamic load rating, and the dynamic equivalent load of the spherical roller bearing is indicated in Formula A. If the spherical roller bearing unit is being used at a fixed rotating speed, the life is indicated as time. This is shown in Formula B.

$$A. L_{10} = \left(\frac{C_r}{P_r} \right)^{\frac{10}{3}}$$

$$B. L_{10h} = \frac{10^6 L_{10}}{60n} = \frac{10^6}{60n} \left(\frac{C_r}{P_r} \right)^{\frac{10}{3}}$$

L_{10} : Basic Rating Life 10^6 rotations

L_{10h} : Rated Life (hr)

C_r : Basic Dynamic Load Rating
(kN)

P_r : Dynamic equivalent Load (kN)

n : Speed (min^{-1})

Models and Features

SPHERICAL ROLLER BEARING UNITS

2 - Bolt Base Type SN Pillow Block Units



ZS2SN

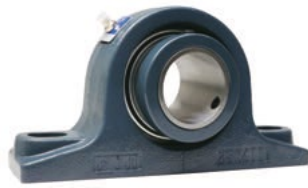

XS2SN

ZS2SN is patented Z LOCK spherical roller bearing unit with SN style housing for the replacement of SN plummer blocks.

XS2SN has the same housing dimensions as the above styles but utilizes the patented Bullet Point setscrews at 120 degrees apart to hold shafting firmly in place.

2 - Bolt Base Pillow Block Units



**ZS2P
ZSE2P**



**XS2P
XSE2P**

ZS2P is a two-bolt pillow block unit with a Z LOCK locking system. This unit is equivalent to many of our competitors SRB style housings. The ends of the housing are milled flat to allow for mounting inside of a fixed frame assembly.

ZSE2P is a two-bolt base pillow block unit with Type E mounting dimensions. It has a footprint that can accommodate both a tapered roller unit and a spherical roller unit for most shaft sizes.

XS2P and **XSE2P** have the same housing dimensions as the above styles but utilizes the patented Bullet Point setscrews at 120 degrees apart to hold shafting firmly in place.

4 - Bolt Flange Units



**ZS4F
ZSE4F**



**XS4F
XSE4F**

ZS4F is a four-bolt flange unit with standard spherical roller unit mounting dimensions and a compact footprint for areas with limited space.

ZSE4F is a four-bolt flange unit with Type E tapered roller unit mounting dimensions. This makes for easy replacement of Type E units when the features of a spherical roller unit are more desirable.

XS4F and **XSE4F** have the same housing dimensions as the above styles but utilizes the patented Bullet Point setscrews at 120 degrees apart to hold shafting firmly in place.

Flange Cartridge Units



ZS4FC



XS4FC

ZS4FC is a flange cartridge unit with pilot mounting dimensions that are the same as medium duty ball bearing units for easy upgrading to a heavier duty series. The threaded withdrawal holes allow for quick and easy dismounting.

XS4FC has the same housing dimensions as the above styles but utilizes the patented Bullet Point setscrews at 120 degrees apart to hold shafting firmly in place.

Take - Up Units



ZST



XST

ZST is a take-up unit with rail slots that are compatible with many industrial frame sizes. This unit can safely handle high belt tension and heavy shock loads.

XST has the same housing dimensions as the above styles but utilizes the patented Bullet Point setscrews at 120 degrees apart to hold shafting firmly in place.

4 - Bolt Base Pillow Block Units



ZS4P



XS4P

ZS4P is a four-bolt base pillow block unit with standard spherical roller bearing mounting dimensions. Four mounting bolt-holes create a firm and secure fit to the mounting surface. The ends of the housing are flat to allow for mounting inside of a fixed frame assembly.

XS4P has the same housing dimensions as the above styles but utilizes the patented Bullet Point setscrews at 120 degrees apart to hold shafting firmly in place.

4 - Bolt Base Pillow Block Units (Double Collar)

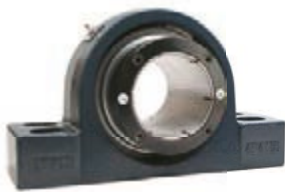

ZDS4P



XDS4P

ZDS4P is the same as the ZS4P but utilizes a double lock. This insert has patented Z LOCK locking mechanism on both the front and back of the inner ring. This additional locking mechanism is helpful in applications where the bearing experiences some thrust loads on the inner ring that could cause a single locking unit to slip.

XDS4P has the same housing dimensions as the above styles but utilizes the patented Bullet Point setscrews at 120 degrees apart to hold shafting firmly in place.

SPHERICAL ROLLER BEARING INSERTS

Spherical Roller Bearing Inserts (Single Collar)



ZS



XS

ZS is a Z LOCK concentric locking insert that utilizes a tapered collar that allows for fast mounting while avoiding damage to shafting that a setscrew unit can cause. The tapered collar keeps the 100% true concentric holding power and does not remove any clearance in the insert by over tightening like the adaptor sleeve locking system can. The unit is tightened down using a hex wrench on the cap screws in a star pattern. The insert can be uninstalled by removing all cap screws and using two of them in the withdrawal holes to disengage the collar.

XS is a setscrew locking insert that utilizes the patented Bullet Point setscrews at 120 degrees apart to hold shafting firmly in place. This is the most economical type of SRB insert and can be utilized in a wide variety of industrial and agricultural applications.

Spherical Roller Bearing Inserts (Double Collar)



ZDS



XDS

ZDS is the same as the ZS above but utilizes a double lock. This insert has a concentric tapered collar on both the front and back of the inner ring. This additional locking mechanism is helpful in applications where a bearing experiences some thrust loads on the inner ring that could cause a single locking unit to slip.

XDS is the same as the XS above but utilizes a double lock. This insert has a setscrew locking mechanism on both the front and back of the inner ring. This additional locking mechanism is helpful in applications where the bearing experiences some thrust loads on the inner ring that could cause a single locking unit to slip.

Models and Features

SPHERICAL ROLLER BEARING UNITS

2 - Bolt Base Type SN Pillow Block Units



ZS2SN

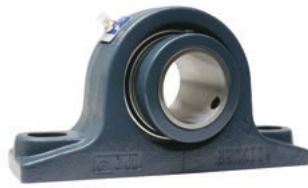

XS2SN

ZS2SN is patented Z LOCK spherical roller bearing unit with SN style housing for the replacement of SN plummer blocks.

XS2SN has the same housing dimensions as the above styles but utilizes the patented Bullet Point setscrews at 120 degrees apart to hold shafting firmly in place.

2 - Bolt Base Pillow Block Units



**ZS2P
ZSE2P**



**XS2P
XSE2P**

ZS2P is a two-bolt pillow block unit with a Z LOCK locking system. This unit is equivalent to many of our competitors SRB style housings. The ends of the housing are milled flat to allow for mounting inside of a fixed frame assembly.

ZSE2P is a two-bolt base pillow block unit with Type E mounting dimensions. It has a footprint that can accommodate both a tapered roller unit and a spherical roller unit for most shaft sizes.

XS2P and **XSE2P** have the same housing dimensions as the above styles but utilizes the patented Bullet Point setscrews at 120 degrees apart to hold shafting firmly in place.

4 - Bolt Flange Units



**ZS4F
ZSE4F**



**XS4F
XSE4F**

ZS4F is a four-bolt flange unit with standard spherical roller unit mounting dimensions and a compact footprint for areas with limited space.

ZSE4F is a four-bolt flange unit with Type E tapered roller unit mounting dimensions. This makes for easy replacement of Type E units when the features of a spherical roller unit are more desirable.

XS4F and **XSE4F** have the same housing dimensions as the above styles but utilizes the patented Bullet Point setscrews at 120 degrees apart to hold shafting firmly in place.

Flange Cartridge Units



ZS4FC



XS4FC

ZS4FC is a flange cartridge unit with pilot mounting dimensions that are the same as medium duty ball bearing units for easy upgrading to a heavier duty series. The threaded withdrawal holes allow for quick and easy dismounting.

XS4FC has the same housing dimensions as the above styles but utilizes the patented Bullet Point setscrews at 120 degrees apart to hold shafting firmly in place.

Take - Up Units



ZST



XST

ZST is a take-up unit with rail slots that are compatible with many industrial frame sizes. This unit can safely handle high belt tension and heavy shock loads.

XST has the same housing dimensions as the above styles but utilizes the patented Bullet Point setscrews at 120 degrees apart to hold shafting firmly in place.

4 - Bolt Base Pillow Block Units



ZS4P



XS4P

ZS4P is a four-bolt base pillow block unit with standard spherical roller bearing mounting dimensions. Four mounting bolt-holes create a firm and secure fit to the mounting surface. The ends of the housing are flat to allow for mounting inside of a fixed frame assembly.

XS4P has the same housing dimensions as the above styles but utilizes the patented Bullet Point setscrews at 120 degrees apart to hold shafting firmly in place.

4 - Bolt Base Pillow Block Units (Double Collar)

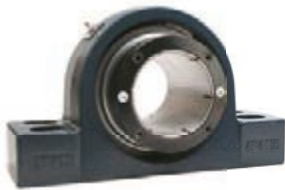

ZDS4P

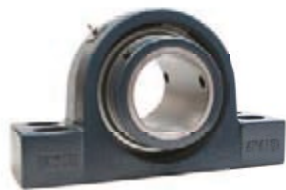

XDS4P

ZDS4P is the same as the ZS4P but utilizes a double lock. This insert has patented Z LOCK locking mechanism on both the front and back of the inner ring. This additional locking mechanism is helpful in applications where the bearing experiences some thrust loads on the inner ring that could cause a single locking unit to slip.

XDS4P has the same housing dimensions as the above styles but utilizes the patented Bullet Point setscrews at 120 degrees apart to hold shafting firmly in place.

SPHERICAL ROLLER BEARING INSERTS

Spherical Roller Bearing Inserts (Single Collar)



ZS



XS

ZS is a Z LOCK concentric locking insert that utilizes a tapered collar that allows for fast mounting while avoiding damage to shafting that a setscrew unit can cause. The tapered collar keeps the 100% true concentric holding power and does not remove any clearance in the insert by over tightening like the adaptor sleeve locking system can. The unit is tightened down using a hex wrench on the cap screws in a star pattern. The insert can be uninstalled by removing all cap screws and using two of them in the withdrawal holes to disengage the collar.

XS is a setscrew locking insert that utilizes the patented Bullet Point setscrews at 120 degrees apart to hold shafting firmly in place. This is the most economical type of SRB insert and can be utilized in a wide variety of industrial and agricultural applications.

Spherical Roller Bearing Inserts (Double Collar)



ZDS



XDS

ZDS is the same as the ZS above but utilizes a double lock. This insert has a concentric tapered collar on both the front and back of the inner ring. This additional locking mechanism is helpful in applications where a bearing experiences some thrust loads on the inner ring that could cause a single locking unit to slip.

XDS is the same as the XS above but utilizes a double lock. This insert has a setscrew locking mechanism on both the front and back of the inner ring. This additional locking mechanism is helpful in applications where the bearing experiences some thrust loads on the inner ring that could cause a single locking unit to slip.

2 - Bolt Base Type SN Pillow Block Units

ZS2SN

Cylindrical bore
(with Z Lock)

d 40 ~ 100 mm

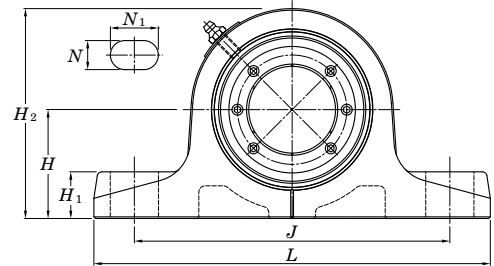
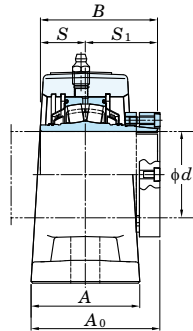

Shaft Dia. mm d	Dimensions mm											
	H	L	A	J	N	N_1	H_1	H_2	A_0	B	S	S_1
40	60	205	60	164.8	15	24.8	25	112	68.9	64.3	25.4	38.9
45	60	205	60	167.5	15	22.5	25	115	72.1	67.5	25.4	42.1
50	70	255	70	203	20	31	28	130	81.8	72.2	25.4	46.8
55	70	255	70	203	20	31	30	135	81	74.6	28.6	46
60 65	80	280	80	220.5	20	33.5	30	155	89.6	81.4	31.8	49.6
70 75	95	316	90	256.4	25	34.1	32	176	104.5	91.3	31.8	59.5
80	100	345	100	281.8	25	34	35	198	115.1	103.6	38.5	65.1
85	112	345	100	280.2	25	38	35	210	115.1	103.6	38.5	65.1
90	112	380	110	309.9	29	43.1	40	218	120.1	103.6	38.5	65.1
100	125	410	120	335.2	29	46.8	45	239	132.6	113.9	41.3	72.6

XS2SN
Cylindrical bore
(with set screw collar lock)
d 40 ~ 100 mm

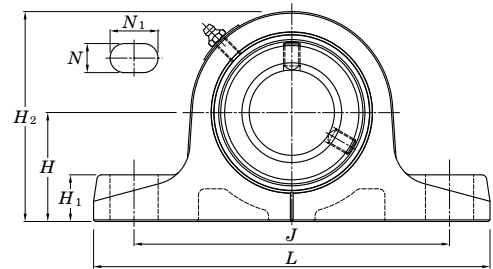
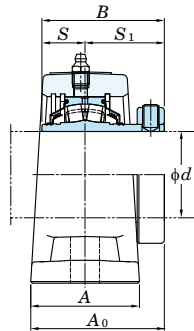

Unit No.	Bearing No.	Unit No.	Bearing No.	Housing No.	Bolt Size	Basic Load Ratings kN		Interchange to SN Plummer Block Units
						C_r	C_{0r}	
ZS2SN408	ZS408	XS2SN408	XS408	2SN408	M12	88.7	101.1	SN509
ZS2SN409	ZS409	XS2SN409	XS409	2SN409	M12	92.6	108.8	SN510
ZS2SN410	ZS410	XS2SN410	XS410	2SN410	M16	96.4	116.9	SN511
ZS2SN411	ZS411	XS2SN411	XS411	2SN411	M16	120.8	146.8	SN512
ZS2SN412	ZS412	XS2SN412	XS412	2SN413	M16	173.3	220.4	SN513
ZS2SN413	ZS413	XS2SN413	XS413					SN515
ZS2SN414	ZS414	XS2SN414	XS414	2SN415	M20	186.8	244.4	SN516
ZS2SN415	ZS415	XS2SN415	XS415					SN517
ZS2SN416	ZS416	XS2SN416	XS416	2SN416	M20	284.1	383.7	SN518
ZS2SN417	ZS417	XS2SN417	XS417	2SN417	M20	284.1	383.7	SN519
ZS2SN418	ZS418	XS2SN418	XS418	2SN418	M24	284.1	383.7	SN520
ZS2SN420	ZS420	XS2SN420	XS420	2SN420	M24	364	497.2	SN522

2 - Bolt Base Type SN Pillow Block Units

ZDS2SN

**Cylindrical bore
(with Z Lock (both))
 d 60 ~ 100 mm**

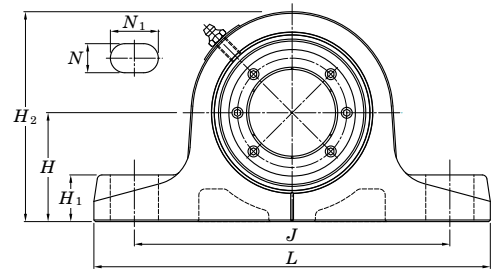
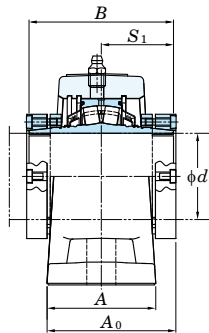
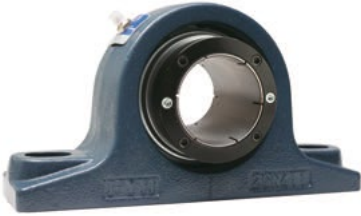

Shaft Dia. mm d	Dimensions mm										
	H	L	A	J	N	N_1	H_1	H_2	A_0	B	S_1
60 65	80	280	80	220.5	20	33.5	30	155	89.6	99.2	49.6
70 75	95	316	90	256.4	25	34.1	32	176	104.5	119	59.5
80	100	345	100	281.8	25	34	35	198	115.1	130.2	65.1
85	112	345	100	280.2	25	38	35	210	115.1	130.2	65.1
90	112	380	110	309.9	29	43.1	40	218	120.1	130.2	65.1
100	125	410	120	335.2	29	46.8	45	239	132.6	145.2	72.6

XDS2SN
Cylindrical bore
(with set screw collar lock (both))
d 60 ~ 100 mm

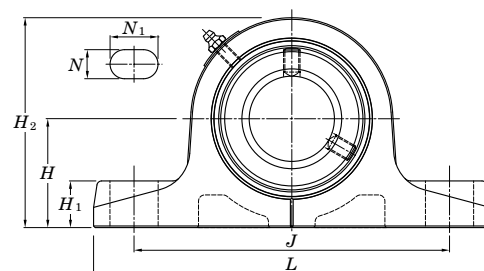
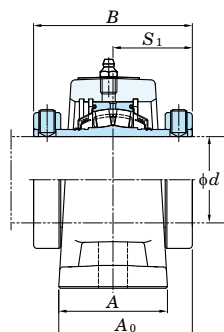

Unit No.	Bearing No.	Unit No.	Bearing No.	Housing No.	Bolt Size	Basic Load Ratings kN		Interchange to SN Plummer Block Units
						C_r	C_{0r}	
ZDS2SN412 ZDS2SN413	ZDS412 ZDS413	XDS2SN412 XDS2SN413	XDS412 XDS413	2SN413	M16	173.3	220.4	SN513 SN515
ZDS2SN414 ZDS2SN415	ZDS414 ZDS415	XDS2SN414 XDS2SN415	XDS414 XDS415	2SN415	M20	186.8	244.4	SN516 SN517
ZDS2SN416	ZDS416	XDS2SN416	XDS416	2SN416	M20	284.1	383.7	SN518
ZDS2SN417	ZDS417	XDS2SN417	XDS417	2SN417	M20	284.1	383.7	SN519
ZDS2SN418	ZDS418	XDS2SN418	XDS418	2SN418	M24	284.1	383.7	SN520
ZDS2SN420	ZDS420	XDS2SN420	XDS420	2SN420	M24	364	497.2	SN522

2 - Bolt Base Pillow Block Units

ZS2P

Cylindrical bore
(with Z Lock)

d 1 3/8 ~ 4 inch
40 ~ 100 mm

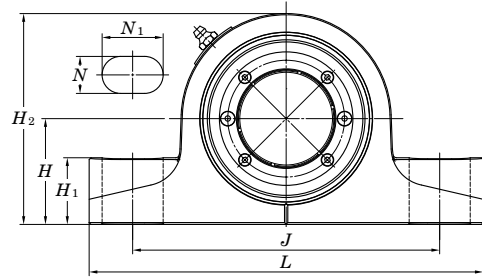
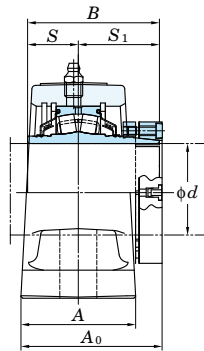

Shaft Dia. inch mm d	Dimensions inch mm											
	H	L	A	J	N	N_1	H_1	H_2	A_0	B	S	S_1
1 3/8 1 7/16 1 1/2 40	1 7/8 47.6	6 7/8 175	2 5/32 55	5 9/32 134	19/32 15	1 3/32 28	1 1/4 32	3 25/32 96	2 5/8 66.4	2.531 64.3	1 25.4	1.531 38.9
1 11/16 1 3/4 45	2 1/8 54	7 3/8 187	2 3/8 60	5 25/32 147	19/32 15	1 3/32 28	1 5/16 33	4 1/4 108	2 27/32 72.1	2.657 67.5	1 25.4	1.657 42.1
1 15/16 50 2	2 1/4 57.2	8 3/8 213	2 7/16 62	6 17/32 166	25/32 20	1 5/16 33	1 3/8 35	4 1/2 114	3 1/16 77.8	2.843 72.2	1 25.4	1.843 46.8
55 2 3/16 2 1/4	2 1/2 63.5	8 7/8 225	2 5/8 67	6 7/8 175	25/32 20	1 3/16 30	1 5/8 41	4 31/32 126	3 1/8 79.5	2.937 74.6	1.126 28.6	1.811 46
60 2 7/16 2 1/2 65	2 3/4 69.8	9 1/4 235	2 7/8 73	7 9/32 185	25/32 20	1 3/16 30	1 25/32 45	5 19/32 142	3 3/8 86.1	3.205 81.4	1.252 31.8	1.953 49.6
70 2 11/16 2 3/4 2 15/16 75 3	3 1/4 82.6	10 7/16 265	3 76	8 9/32 210	15/16 24	1 9/32 32	1 7/8 48	6 3/8 162	3 13/16 97	3.594 91.3	1.252 31.8	2.343 59.5
80 3 1/4 85 3 7/16 3 1/2 90	3 3/4 95.2	13 330	3 3/8 86	10 5/16 262	1 1/16 27	1 23/32 44	2 1/4 57	7 15/32 190	4 1/4 108.1	4.079 103.6	1.516 38.5	2.563 65.1
100 3 15/16 4	4 1/4 108	15 1/4 387	3 3/4 95	11 1/4 286	1 5/32 29	2 5/16 59	2 17/32 64	8 11/32 212	4 23/32 120.1	4.484 113.9	1.626 41.3	2.858 72.6

XS2P

Cylindrical bore

(with set screw collar lock)

d 1 3/8 ~ 4 inch

40 ~ 100 mm

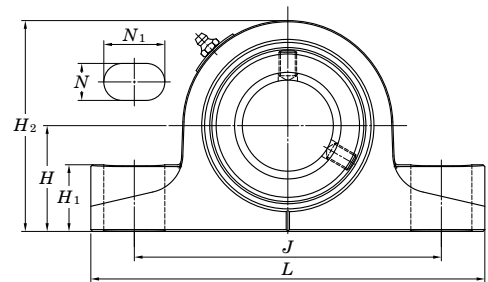
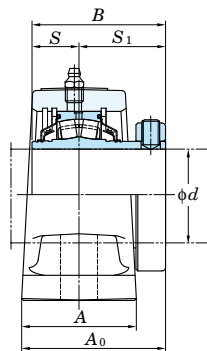

Unit No.	Bearing No.	Unit No.	Bearing No.	Housing No.	Bolt Size	Basic Load Ratings	
						C_r	C_{0r}
						kN	
						inch	mm
ZS2P408-22	ZS408-22	XS2P408-22	XS408-22	2P408	1/2 M12	88.7	101.1
ZS2P408-23	ZS408-23	XS2P408-23	XS408-23				
ZS2P408-24	ZS408-24	XS2P408-24	XS408-24				
ZS2P408	ZS408	XS2P408	XS408				
ZS2P409-27	ZS409-27	XS2P409-27	XS409-27	2P409	1/2 M12	92.6	108.8
ZS2P409-28	ZS409-28	XS2P409-28	XS409-28				
ZS2P409	ZS409	XS2P409	XS409				
ZS2P410-31	ZS410-31	XS2P410-31	XS410-31	2P410	5/8 M16	96.4	116.9
ZS2P410	ZS410	XS2P410	XS410				
ZS2P410-32	ZS410-32	XS2P410-32	XS410-32				
ZS2P411	ZS411	XS2P411	XS411	2P411	5/8 M16	120.8	146.8
ZS2P411-35	ZS411-35	XS2P411-35	XS411-35				
ZS2P411-36	ZS411-36	XS2P411-36	XS411-36				
ZS2P412	ZS412	XS2P412	XS412	2P413	5/8 M16	173.3	220.4
ZS2P413-39	ZS413-39	XS2P413-39	XS413-39				
ZS2P413-40	ZS413-40	XS2P413-40	XS413-40				
ZS2P413	ZS413	XS2P413	XS413				
ZS2P414	ZS414	XS2P414	XS414	2P415	3/4 M20	186.8	244.4
ZS2P415-43	ZS415-43	XS2P415-43	XS415-43				
ZS2P415-44	ZS415-44	XS2P415-44	XS415-44				
ZS2P415-47	ZS415-47	XS2P415-47	XS415-47				
ZS2P415	ZS415	XS2P415	XS415				
ZS2P415-48	ZS415-48	XS2P415-48	XS415-48				
ZS2P416	ZS416	XS2P416	XS416	2P418	7/8 M22	284.1	383.7
ZS2P417-52	ZS417-52	XS2P417-52	XS417-52				
ZS2P417	ZS417	XS2P417	XS417				
ZS2P418-55	ZS418-55	XS2P418-55	XS418-55				
ZS2P418-56	ZS418-56	XS2P418-56	XS418-56				
ZS2P418	ZS418	XS2P418	XS418				
ZS2P420	ZS420	XS2P420	XS420	2P420	1 M24	364	497.2
ZS2P420-63	ZS420-63	XS2P420-63	XS420-63				
ZS2P420-64	ZS420-64	XS2P420-64	XS420-64				

2 - Bolt Base Type E Pillow Block Units

ZSE2P

Cylindrical bore
(with Z Lock)

d 1 3/8 ~ 4 inch
40 ~ 100 mm

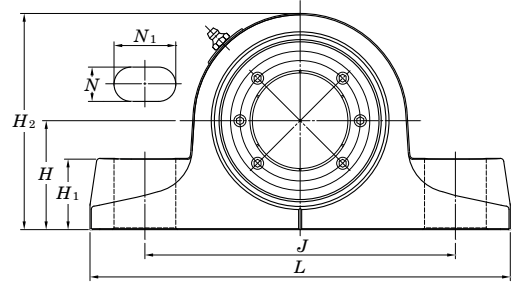
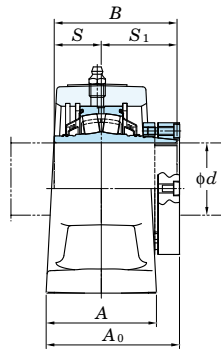

Shaft Dia. inch mm d	Dimensions inch mm											
	H	L	A	J	N	N_1	H_1	H_2	A_0	B	S	S_1
1 3/8 1 7/16 1 1/2 40	1 7/8 47.6	7 3/8 187	2 5/32 55	5 9/32 134	19/32 15	1 3/32 28	1 1/4 32	3 25/32 96	2 5/8 66.4	2.531 64.3	1 25.4	1.531 38.9
1 11/16 1 3/4 45	2 1/8 54	7 7/8 200	2 3/8 60	5 25/32 147	19/32 15	1 3/32 28	1 5/16 33	4 1/4 108	2 27/32 72.1	2.657 67.5	1 25.4	1.657 42.1
1 15/16 50 2	2 1/4 57.2	8 29/32 226	2 7/16 62	6 17/32 166	25/32 20	1 5/16 33	1 3/8 35	4 1/2 114	3 1/16 77.8	2.843 72.2	1 25.4	1.843 46.8
55 2 3/16 2 1/4	2 1/2 63.5	9 21/32 245	2 5/8 67	7 1/8 181	25/32 20	1 13/32 36	1 5/8 41	4 31/32 126	3 1/8 79.5	2.937 74.6	1.126 28.6	1.811 46
60 2 7/16 2 1/2 65	2 3/4 69.8	10 1/4 260	2 7/8 73	7 11/16 195	25/32 20	1 9/16 40	1 25/32 45	5 19/32 142	3 3/8 86.1	3.205 81.4	1.252 31.8	1.953 49.6
70 2 11/16 2 3/4 2 15/16 75 3	3 1/8 79.5	11 5/8 295	3 76	8 11/16 221	15/16 24	1 11/16 43	1 25/32 45	6 1/4 159	3 13/16 97	3.594 91.3	1.252 31.8	2.343 59.5
80 3 1/4 85 3 7/16 3 1/2 90	3 3/4 95.2	13 1/2 343	3 3/8 86	10 5/16 262	1 1/16 27	1 23/32 44	2 1/4 57	7 15/32 190	4 1/4 108.1	4.079 103.6	1.516 38.5	2.563 65.1
100 3 15/16 4	4 1/8 104.9	15 1/4 387	3 3/4 95	11 1/4 286	1 5/32 29	2 5/16 59	2 13/32 61	8 7/32 209	4 23/32 120.1	4.484 113.9	1.626 41.3	2.858 72.6

XSE2P

Cylindrical bore

(with set screw collar lock)

d 1 3/8 ~ 4 inch

40 ~ 100 mm

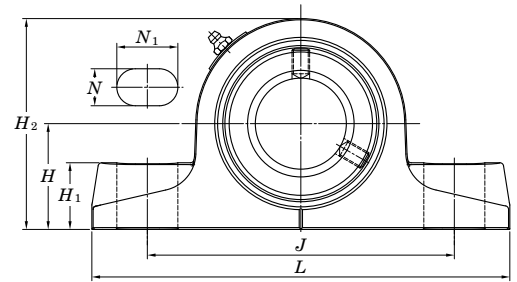
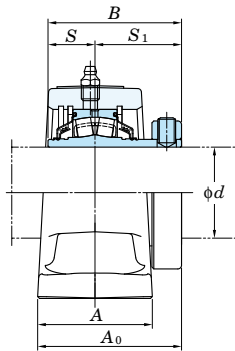

Unit No.	Bearing No.	Unit No.	Bearing No.	Housing No.	Bolt Size	Basic Load Ratings	
						inch	mm
ZSE2P408-22	ZS408-22	XSE2P408-22	XS408-22	E2P08	1/2 M12	88.7	101.1
ZSE2P408-23	ZS408-23	XSE2P408-23	XS408-23				
ZSE2P408-24	ZS408-24	XSE2P408-24	XS408-24				
ZSE2P408	ZS408	XSE2P408	XS408				
ZSE2P409-27	ZS409-27	XSE2P409-27	XS409-27	E2P09	1/2 M12	92.6	108.8
ZSE2P409-28	ZS409-28	XSE2P409-28	XS409-28				
ZSE2P409	ZS409	XSE2P409	XS409				
ZSE2P410-31	ZS410-31	XSE2P410-31	XS410-31	E2P10	5/8 M16	96.4	116.9
ZSE2P410	ZS410	XSE2P410	XS410				
ZSE2P410-32	ZS410-32	XSE2P410-32	XS410-32				
ZSE2P411	ZS411	XSE2P411	XS411	E2P11	5/8 M16	120.8	146.8
ZSE2P411-35	ZS411-35	XSE2P411-35	XS411-35				
ZSE2P411-36	ZS411-36	XSE2P411-36	XS411-36				
ZSE2P412	ZS412	XSE2P412	XS412	E2P13	5/8 M16	173.3	220.4
ZSE2P413-39	ZS413-39	XSE2P413-39	XS413-39				
ZSE2P413-40	ZS413-40	XSE2P413-40	XS413-40				
ZSE2P413	ZS413	XSE2P413	XS413				
ZSE2P414	ZS414	XSE2P414	XS414	E2P15	3/4 M20	186.8	244.4
ZSE2P415-43	ZS415-43	XSE2P415-43	XS415-43				
ZSE2P415-44	ZS415-44	XSE2P415-44	XS415-44				
ZSE2P415-47	ZS415-47	XSE2P415-47	XS415-47				
ZSE2P415	ZS415	XSE2P415	XS415				
ZSE2P415-48	ZS415-48	XSE2P415-48	XS415-48				
ZSE2P416	ZS416	XSE2P416	XS416	E2P18	7/8 M22	284.1	383.7
ZSE2P417-52	ZS417-52	XSE2P417-52	XS417-52				
ZSE2P417	ZS417	XSE2P417	XS417				
ZSE2P418-55	ZS418-55	XSE2P418-55	XS418-55				
ZSE2P418-56	ZS418-56	XSE2P418-56	XS418-56				
ZSE2P418	ZS418	XSE2P418	XS418				
ZSE2P420	ZS420	XSE2P420	XS420	E2P20	1 M24	364	497.2
ZSE2P420-63	ZS420-63	XSE2P420-63	XS420-63				
ZSE2P420-64	ZS420-64	XSE2P420-64	XS420-64				

4 - Bolt Flange Units

ZS4F

Cylindrical bore
(with Z Lock)

d 1 3/8 ~ 4 inch
40 ~ 100 mm

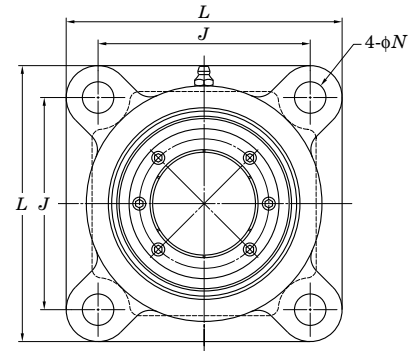
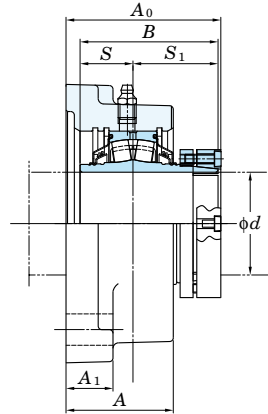

Shaft Dia. inch mm d	Dimensions inch mm								
	L	A	J	N	A_1	A_0	B	S	S_1
1 3/8 1 7/16 1 1/2 40	4 3/4 121	2 3/32 53	3 17/32 89.7	35/64 14	3/4 19	2 3/4 70.2	2.531 64.3	1 25.4	1.531 38.9
1 11/16 1 3/4 45	5 1/8 130	2 5/32 55	3 57/64 98.8	35/64 14	3/4 19	2 31/32 75.4	2.657 67.5	1 25.4	1.657 42.1
1 15/16 50 2	5 5/16 135	2 3/32 55	4 1/16 103.2	35/64 14	3/4 19	3 5/32 80.2	2.843 72.2	1 25.4	1.843 46.8
55 2 3/16 2 1/4	5 29/32 150	2 9/32 58	4 33/64 114.7	21/32 17	1 1/32 26	3 1/4 82.2	2.937 74.6	1.126 28.6	1.811 46
60 2 7/16 2 1/2	6 1/8 156	2 9/16 65	4 25/32 121.4	21/32 17	1 1/32 26	3 17/32 89.3	3.205 81.4	1.252 31.8	1.953 49.6
65 70 2 11/16 2 3/4 2 15/16	7 7/32 183	2 5/8 67	5 9/16 141.3	7/8 22	1 1/32 26	3 29/32 99.2	3.594 91.3	1.252 31.8	2.343 59.5
75 3 80 3 1/4	8 9/32 210	3 5/32 80	6 23/32 170.7	7/8 22	1 5/32 29	4 3/8 111.5	4.079 103.6	1.516 38.5	2.563 65.1
85 3 7/16 3 1/2 90 100 3 15/16 4	9 1/4 235	3 19/32 91	7 39/64 193.3	63/64 25	1 3/16 30	4 27/32 123	4.484 113.9	1.626 41.3	2.858 72.6

XS4F

Cylindrical bore
(with set screw collar lock)

d 1 3/8 ~ 4 inch

40 ~ 100 mm

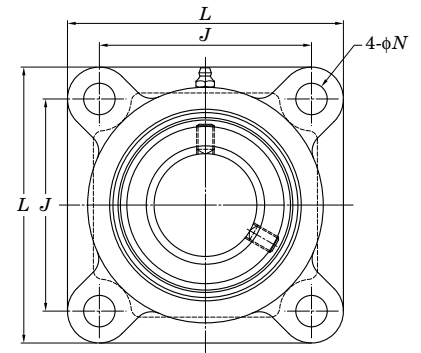
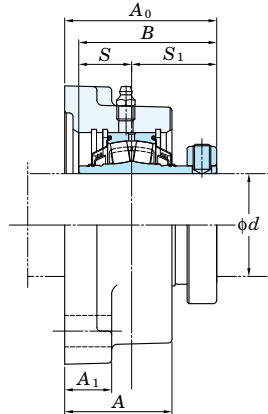

Unit No.	Bearing No.	Unit No.	Bearing No.	Housing No.	Bolt Size	Basic Load Ratings	
						C_r	C_{0r}
						kN	
						inch	
						mm	
ZS4F408-22	ZS408-22	XS4F408-22	XS408-22	4F408	1/2 M12	88.7	101.1
ZS4F408-23	ZS408-23	XS4F408-23	XS408-23				
ZS4F408-24	ZS408-24	XS4F408-24	XS408-24				
ZS4F408	ZS408	XS4F408	XS408				
ZS4F409-27	ZS409-27	XS4F409-27	XS409-27	4F409	1/2 M12	92.6	108.8
ZS4F409-28	ZS409-28	XS4F409-28	XS409-28				
ZS4F409	ZS409	XS4F409	XS409				
ZS4F410-31	ZS410-31	XS4F410-31	XS410-31	4F410	1/2 M12	96.4	116.9
ZS4F410	ZS410	XS4F410	XS410				
ZS4F410-32	ZS410-32	XS4F410-32	XS410-32				
ZS4F411	ZS411	XS4F411	XS411	4F411	5/8 M16	120.8	146.8
ZS4F411-35	ZS411-35	XS4F411-35	XS411-35				
ZS4F411-36	ZS411-36	XS4F411-36	XS411-36				
ZS4F412	ZS412	XS4F412	XS412	4F413	5/8 M16	173.3	220.4
ZS4F413-39	ZS413-39	XS4F413-39	XS413-39				
ZS4F413-40	ZS413-40	XS4F413-40	XS413-40				
ZS4F413	ZS413	XS4F413	XS413				
ZS4F414	ZS414	XS4F414	XS414	4F415	3/4 M20	186.8	244.4
ZS4F415-43	ZS415-43	XS4F415-43	XS415-43				
ZS4F415-44	ZS415-44	XS4F415-44	XS415-44				
ZS4F415-47	ZS415-47	XS4F415-47	XS415-47				
ZS4F415	ZS415	XS4F415	XS415				
ZS4F415-48	ZS415-48	XS4F415-48	XS415-48				
ZS4F416	ZS416	XS4F416	XS416	4F418	3/4 M20	284.1	383.7
ZS4F417-52	ZS417-52	XS4F417-52	XS417-52				
ZS4F417	ZS417	XS4F417	XS417				
ZS4F418-55	ZS418-55	XS4F418-55	XS418-55				
ZS4F418-56	ZS418-56	XS4F418-56	XS418-56				
ZS4F418	ZS418	XS4F418	XS418				
ZS4F420	ZS420	XS4F420	XS420	4F420	7/8 M22	364	497.2
ZS4F420-63	ZS420-63	XS4F420-63	XS420-63				
ZS4F420-64	ZS420-64	XS4F420-64	XS420-64				

4 - Bolt Type E Flange Units

ZSE4F

Cylindrical bore
(with Z Lock)

d 1 3/8 ~ 4 inch
40 ~ 100 mm

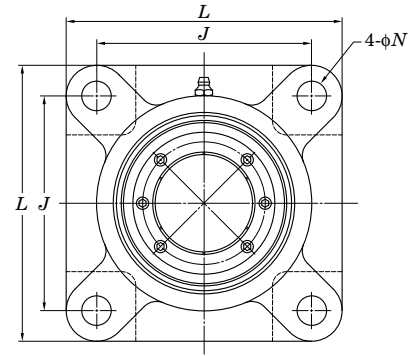
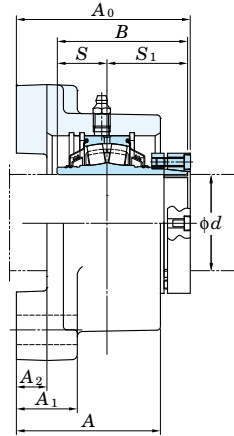

Shaft Dia. inch mm d	Dimensions inch mm									
	L	A	J	N	A_1	A_2	A_0	B	S	S_1
1 3/8 1 7/16 1 1/2 40	4 19/32 117	2 15/32 63	3 1/2 88.9	35/64 14	1 1/16 27	1/2 13	3 1/16 77.8	2.531 64.3	1 25.4	1.531 38.9
1 11/16 1 3/4 45	5 11/32 136	2 15/16 75	4 1/8 104.9	35/64 14	1 3/16 30	5/8 16	3 1/2 88.8	2.657 67.5	1 25.4	1.657 42.1
1 15/16 50 2	5 5/8 143	2 15/16 75	4 3/8 111	35/64 14	1 3/16 30	5/8 16	3 5/8 92	2.843 72.2	1 25.4	1.843 46.8
55 2 3/16 2 1/4	6 1/4 159	3 9/32 83	4 7/8 123.7	21/32 17	1 3/8 35	23/32 18	3 7/8 98.2	2.937 74.6	1.126 28.6	1.811 46
60 2 7/16 2 1/2	6 7/8 175	3 11/32 85	5 3/8 136.4	21/32 17	1 1/2 38	25/32 20	4 3/16 106.3	3.205 81.4	1.252 31.8	1.953 49.6
70 2 11/16 2 3/4 2 15/16	7 3/4 197	3 13/16 97	6 152.4	7/8 22	1 5/8 41	15/16 24	4 11/16 119	3.594 91.3	1.252 31.8	2.343 59.5
75 3										
80 3 1/4										
85 3 7/16 3 1/2	9 1/4 235	4 9/32 109	7 177.8	7/8 22	1 7/8 48	31/32 24.5	5 5/16 135.1	4.079 103.6	1.516 38.5	2.563 65.1
90										
100 3 15/16 4	10 1/4 260	5 1/2 140	7 3/4 196.9	63/64 25	2 1/8 54	1 3/32 28	6 1/2 165.2	4.484 113.9	1.626 41.3	2.858 72.6

XSE4F

Cylindrical bore

(with set screw collar lock)

d 1 3/8 ~ 4 inch

40 ~ 100 mm

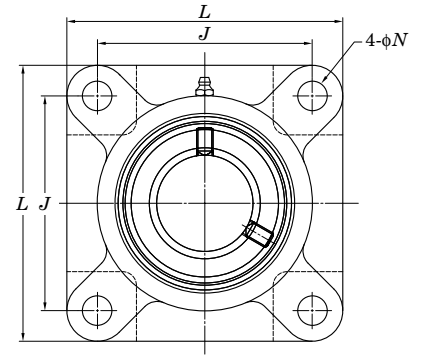
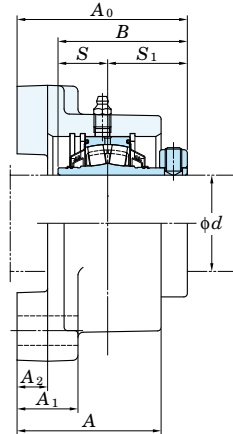

Unit No.	Bearing No.	Unit No.	Bearing No.	Housing No.	Bolt Size	Basic Load Ratings	
						C_r	C_{0r}
						kN	
						inch	
						mm	
ZSE4F408-22	ZS408-22	XSE4F408-22	XS408-22	E4F408	1/2 M12	88.7	101.1
ZSE4F408-23	ZS408-23	XSE4F408-23	XS408-23				
ZSE4F408-24	ZS408-24	XSE4F408-24	XS408-24				
ZSE4F408	ZS408	XSE4F408	XS408				
ZSE4F409-27	ZS409-27	XSE4F409-27	XS409-27	E4F409	1/2 M12	92.6	108.8
ZSE4F409-28	ZS409-28	XSE4F409-28	XS409-28				
ZSE4F409	ZS409	XSE4F409	XS409				
ZSE4F410-31	ZS410-31	XSE4F410-31	XS410-31	E4F410	1/2 M12	96.4	116.9
ZSE4F410	ZS410	XSE4F410	XS410				
ZSE4F410-32	ZS410-32	XSE4F410-32	XS410-32				
ZSE4F411	ZS411	XSE4F411	XS411	E4F411	5/8 M16	120.8	146.8
ZSE4F411-35	ZS411-35	XSE4F411-35	XS411-35				
ZSE4F411-36	ZS411-36	XSE4F411-36	XS411-36				
ZSE4F412	ZS412	XSE4F412	XS412	E4F413	5/8 M16	173.3	220.4
ZSE4F413-39	ZS413-39	XSE4F413-39	XS413-39				
ZSE4F413-40	ZS413-40	XSE4F413-40	XS413-40				
ZSE4F413	ZS413	XSE4F413	XS413				
ZSE4F414	ZS414	XSE4F414	XS414	E4F415	3/4 M20	186.8	244.4
ZSE4F415-43	ZS415-43	XSE4F415-43	XS415-43				
ZSE4F415-44	ZS415-44	XSE4F415-44	XS415-44				
ZSE4F415-47	ZS415-47	XSE4F415-47	XS415-47				
ZSE4F415	ZS415	XSE4F415	XS415				
ZSE4F415-48	ZS415-48	XSE4F415-48	XS415-48				
ZSE4F416	ZS416	XSE4F416	XS416	E4F418	3/4 M20	284.1	383.7
ZSE4F417-52	ZS417-52	XSE4F417-52	XS417-52				
ZSE4F417	ZS417	XSE4F417	XS417				
ZSE4F418-55	ZS418-55	XSE4F418-55	XS418-55				
ZSE4F418-56	ZS418-56	XSE4F418-56	XS418-56	E4F420	7/8 M22	364	497.2
ZSE4F418	ZS418	XSE4F418	XS418				
ZSE4F420	ZS420	XSE4F420	XS420	E4F420	7/8 M22	364	497.2
ZSE4F420-63	ZS420-63	XSE4F420-63	XS420-63				
ZSE4F420-64	ZS420-64	XSE4F420-64	XS420-64				

Take - Up Units

ZST Cylindrical bore (with Z Lock)

d 1 ¹⁵/₁₆ ~ 3 ¹/₂ inch
50 ~ 90 mm

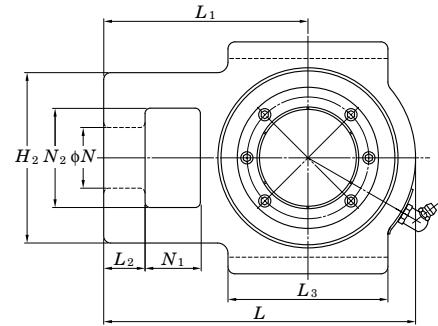
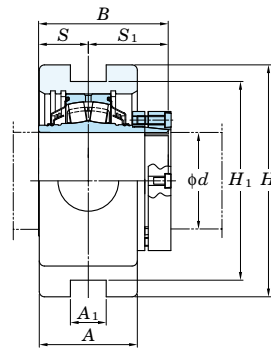

Shaft Dia. inch mm d	Dimensions inch mm														
	A	A ₁	H	H ₁	H ₂	L	L ₁	L ₂	L ₃	N	N ₁	N ₂	B	S	S ₁
1 ¹⁵ / ₁₆ 50 2	2 51	1 ¹¹ / ₁₆ 17.5	4 ³ / ₄ 121	4 101.6	3 ⁵ / ₁₆ 84	6 ³ / ₁₆ 157.2	3 ¹⁵ / ₁₆ 100	1 ¹⁵ / ₁₆ 23.8	3 ⁵ / ₈ 92	1 ¹ / ₈ 28.6	3/4 19.1	1 ¹⁵ / ₁₆ 49.2	2.843 72.2	1 25.4	1.843 46.8
55 2 ³ / ₁₆ 2 ¹ / ₄	2 ⁷ / ₃₂ 56	1 ¹³ / ₁₆ 20.6	5 ¹ / ₄ 133	4 ¹ / ₂ 114.3	3 ²⁷ / ₃₂ 98	7 ¹ / ₁₆ 179.4	4 ⁵ / ₈ 117.5	1 ¹⁵ / ₁₆ 23.8	3 ⁵ / ₈ 92	1 ³ / ₈ 34.9	1 ¹ / ₄ 31.8	2 ¹ / ₄ 57.2	2.937 74.6	1.126 28.6	1.811 46
60 2 ⁷ / ₁₆ 2 ¹ / ₂	2 ⁷ / ₁₆ 62	1 ¹ / ₁₆ 27	5 ⁷ / ₈ 149	5 ¹ / ₈ 130.2	4 ¹ / ₄ 108	7 ²⁵ / ₃₂ 198	5 127	1 ¹⁵ / ₁₆ 23.8	4 ³ / ₈ 111	1 ³ / ₈ 34.9	1 ¹ / ₄ 31.8	2 ¹ / ₂ 63.5	3.205 81.4	1.252 31.8	1.953 49.6
65 70 2 ¹¹ / ₁₆ 2 ³ / ₄ 2 ¹⁵ / ₁₆	2 ¹¹ / ₁₆ 68	1 ¹³ / ₁₆ 46	6 ¹¹ / ₁₆ 170	5 ¹⁵ / ₁₆ 150.8	4 ⁷ / ₈ 124	8 ⁷ / ₈ 225.4	5 ³ / ₄ 146.1	1 ¹ / ₈ 28.6	4 ¹ / ₂ 114.3	1 ⁵ / ₈ 41.3	1 ¹ / ₂ 38.1	2 ³ / ₄ 69.9	3.594 91.3	1.252 31.8	2.343 59.5
75 3 80 3 ¹ / ₄	3 ¹ / ₁₆ 78	1 ¹³ / ₁₆ 46	7 ²⁵ / ₃₂ 198	6 ¹³ / ₁₆ 173	5 ¹ / ₈ 130	10 ¹ / ₁₆ 255.6	6 ³ / ₈ 161.9	1 ¹ / ₁₆ 27	5 ¹ / ₂ 139.7	1 ⁷ / ₈ 47.6	1 ⁵ / ₈ 41.3	2 ⁷ / ₈ 73	4.079 103.6	1.516 38.5	2.563 65.1
85 3 ⁷ / ₁₆ 3 ¹ / ₂															
90															

XST
Cylindrical bore
(with set screw collar lock)
 d 1 ¹⁵/₁₆ ~ 3 ¹/₂ inch
 50 ~ 90 mm

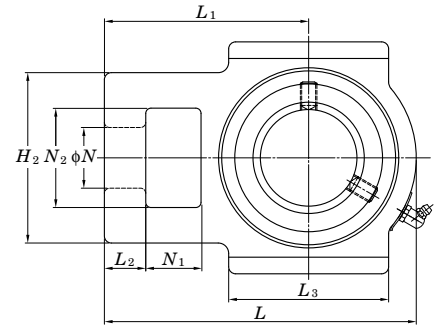
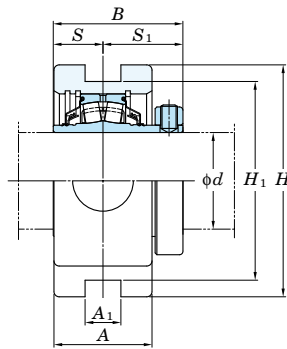

Unit No.	Bearing No.	Unit No.	Bearing No.	Housing No.	Basic Load Ratings kN	
					C_r	C_{0r}
ZST410-31 ZST410 ZST410-32	ZS410-31 ZS410 ZS410-32	XST410-31 XST410 XST410-32	XS410-31 XS410 XS410-32	T410	96.4	116.9
ZST411 ZST411-35 ZST411-36	ZS411 ZS411-35 ZS411-36	XST411 XST411-35 XST411-36	XS411 XS411-35 XS411-36	T411	120.8	146.8
ZST412 ZST413-39 ZST413-40 ZST413	ZS412 ZS413-39 ZS413-40 ZS413	XST412 XST413-39 XST413-40 XST413	XS412 XS413-39 XS413-40 XS413	T413	173.3	220.4
ZST414 ZST415-43 ZST415-44 ZST415-47 ZST415 ZST415-48	ZS414 ZS415-43 ZS415-44 ZS415-47 ZS415 ZS415-48	XST414 XST415-43 XST415-44 XST415-47 XST415 XST415-48	XS414 XS415-43 XS415-44 XS415-47 XS415 XS415-48	T415	186.8	244.4
ZST416 ZST417-52 ZST417 ZST418-55 ZST418-56 ZST418	ZS416 ZS417-52 ZS417 ZS418-55 ZS418-56 ZS418	XST416 XST417-52 XST417 XST418-55 XST418-56 XST418	XS416 XS417-52 XS417 XS418-55 XS418-56 XS418	T418	284.1	383.7

Flange Cartridge Units

ZS4FC
Cylindrical bore
(with Z Lock)
d 1 3/8 ~ 4 inch
 40 ~ 100 mm

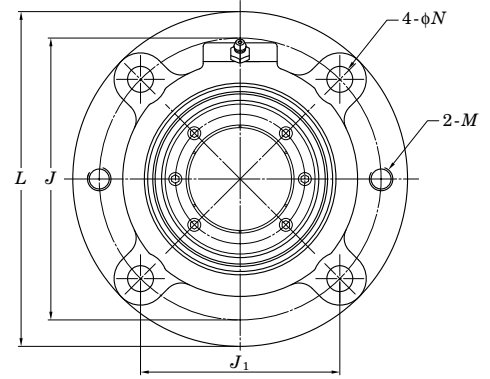
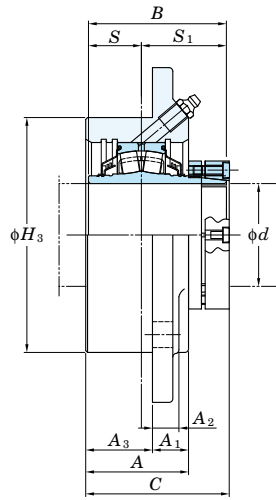

Shaft Dia. inch mm <i>d</i>	Dimensions inch mm													
	<i>L</i>	<i>H</i> ₃	<i>J</i>	<i>J</i> ₁	<i>N</i>	<i>A</i>	<i>A</i> ₁	<i>A</i> ₂	<i>A</i> ₃	<i>C</i>	<i>M</i>	<i>B</i>	<i>S</i>	<i>S</i> ₁
1 3/8 1 7/16 1 1/2 40	5 1/4 133	3.625 92.1	4 3/8 111.1	3 3/32 78.6	15/32 12	1 27/32 46.8	13/16 21	11/16 17.3	1 1/32 26	2 17/32 64.3	3/8-16UNC	2.531 64.3	1 25.4	1.531 38.9
1 11/16 1 3/4 45	6 5/32 156	4.25 107.8	5 1/8 130.2	3 5/8 92.1	9/16 14	1 29/32 48.4	5/8 16	1/2 12.7	1 17/64 32.2	2 23/32 69.1	7/16-14UNC	2.657 67.5	1 25.4	1.657 42.1
1 15/16 50 2	6 3/8 162	4.5 114.3	5 3/8 136.5	3 51/64 96.5	9/16 14	2 50.8	3/4 19	9/16 14.3	1 17/64 32.2	2 55/64 72.6	7/16-14UNC	2.843 72.2	1 25.4	1.843 46.8
55 2 3/16 2 1/4	7 1/8 181	5 127	6 152.4	4 1/4 107.8	35/64 14	2 3/16 55.6	25/32 20	9/16 14.3	1 27/64 36.1	3 76.1	1/2-13UNC	2.937 74.6	1.126 28.6	1.811 46
60 2 7/16 2 1/2	7 5/8 194	5.5 139.7	6 1/2 165.1	4 19/32 116.7	35/64 14	2 1/2 63.5	15/16 24	5/8 15.9	1 9/16 39.7	3 7/16 87.4	1/2-13UNC	3.205 81.4	1.252 31.8	1.953 49.6
65 70 2 11/16 2 3/4 2 15/16	8 3/4 222	6.375 161.9	7 1/2 190.5	5 19/64 134.7	43/64 17	2 5/8 66.7	31/32 25	3/4 19.1	1 5/8 41.3	3 41/64 92.5	5/8-11UNC	3.594 91.3	1.252 31.8	2.343 59.5
75 3 80 3 1/4	10 1/4 260	7.375 187.3	8 5/8 219.1	6 3/32 154.9	29/32 23	3 76.2	1 15/32 38	15/16 23.8	1 33/64 38.5	4 5/32 105.6	3/4-10UNC	4.079 103.6	1.516 38.5	2.563 65.1
85 3 7/16 3 1/2 90 100 3 15/16 4	10 7/8 276	8.125 206.4	9 3/8 238.1	6 5/8 168.4	29/32 23	3 1/2 88.9	1 9/16 40	1 1/4 31.4	1 29/32 48.4	4 9/16 115.9	3/4-10UNC	4.484 113.9	1.626 41.3	2.858 72.6

XS4FC
Cylindrical bore
(with set screw collar lock)
 d 1 3/8 ~ 4 inch
 40 ~ 100 mm

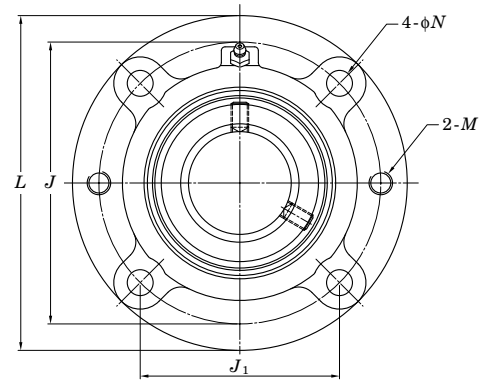
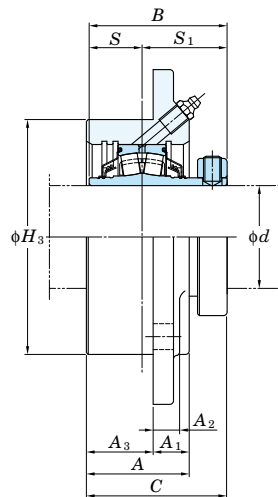

Unit No.	Bearing No.	Unit No.	Bearing No.	Housing No.	Bolt Size	Basic Load Ratings	
						C_r	C_{0r}
					inch		
					mm		
ZS4FC408-22	ZS408-22	XS4FC408-22	XS408-22	4FC408	3/8 M10	88.7	101.1
ZS4FC408-23	ZS408-23	XS4FC408-23	XS408-23				
ZS4FC408-24	ZS408-24	XS4FC408-24	XS408-24				
ZS4FC408	ZS408	XS4FC408	XS408				
ZS4FC409-27	ZS409-27	XS4FC409-27	XS409-27	4FC409	7/6 M12	92.6	108.8
ZS4FC409-28	ZS409-28	XS4FC409-28	XS409-28				
ZS4FC409	ZS409	XS4FC409	XS409				
ZS4FC410-31	ZS410-31	XS4FC410-31	XS410-31	4FC410	7/6 M12	96.4	116.9
ZS4FC410	ZS410	XS4FC410	XS410				
ZS4FC410-32	ZS410-32	XS4FC410-32	XS410-32				
ZS4FC411	ZS411	XS4FC411	XS411	4FC411	1/2 M12	120.8	146.8
ZS4FC411-35	ZS411-35	XS4FC411-35	XS411-35				
ZS4FC411-36	ZS411-36	XS4FC411-36	XS411-36				
ZS4FC412	ZS412	XS4FC412	XS412	4FC413	1/2 M12	173.3	220.4
ZS4FC413-39	ZS413-39	XS4FC413-39	XS413-39				
ZS4FC413-40	ZS413-40	XS4FC413-40	XS413-40				
ZS4FC413	ZS413	XS4FC413	XS413				
ZS4FC414	ZS414	XS4FC414	XS414	4FC415	5/8 M16	186.8	244.4
ZS4FC415-43	ZS415-43	XS4FC415-43	XS415-43				
ZS4FC415-44	ZS415-44	XS4FC415-44	XS415-44				
ZS4FC415-47	ZS415-47	XS4FC415-47	XS415-47				
ZS4FC415	ZS415	XS4FC415	XS415				
ZS4FC415-48	ZS415-48	XS4FC415-48	XS415-48				
ZS4FC416	ZS416	XS4FC416	XS416	4FC418	3/4 M20	284.1	383.7
ZS4FC417-52	ZS417-52	XS4FC417-52	XS417-52				
ZS4FC417	ZS417	XS4FC417	XS417				
ZS4FC418-55	ZS418-55	XS4FC418-55	XS418-55				
ZS4FC418-56	ZS418-56	XS4FC418-56	XS418-56				
ZS4FC418	ZS418	XS4FC418	XS418				
ZS4FC420	ZS420	XS4FC420	XS420	4FC420	3/4 M20	364	497.2
ZS4FC420-63	ZS420-63	XS4FC420-63	XS420-63				
ZS4FC420-64	ZS420-64	XS4FC420-64	XS420-64				

4 - Bolt Base Pillow Block Units

ZS4P

Cylindrical bore
(with Z Lock)

d $2\frac{7}{16} \sim 4$ inch
60 ~ 100 mm

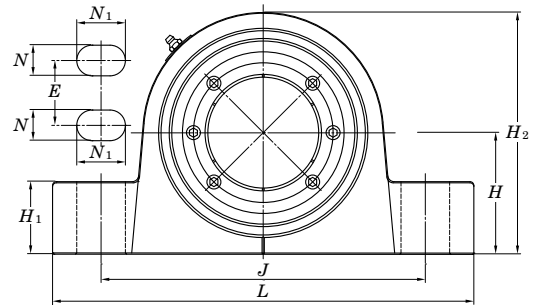
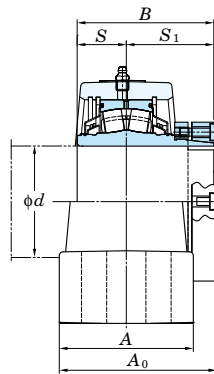

Shaft Dia. inch mm d	Dimensions inch mm												
	H	L	A	J	N	N_1	E	H_1	H_2	A_0	B	S	S_1
60 $2\frac{7}{16}$ $2\frac{1}{2}$ 69.8	$2\frac{3}{4}$ 69.8	$9\frac{1}{4}$ 235	$3\frac{3}{8}$ 86	$7\frac{1}{8}$ 181	$\frac{19}{32}$ 15	$\frac{13}{16}$ 21	$1\frac{3}{4}$ 44	$1\frac{5}{8}$ 41	$5\frac{19}{32}$ 142	$3\frac{21}{32}$ 92.6	3.205 81.4	1.252 31.8	1.953 49.6
65 70 $2\frac{11}{16}$ $2\frac{3}{4}$ $2\frac{15}{16}$ 82.6	$3\frac{1}{4}$ 82.6	$10\frac{7}{16}$ 265	$3\frac{3}{4}$ 95	$8\frac{1}{8}$ 206	$\frac{25}{32}$ 20	$\frac{15}{16}$ 24	$1\frac{7}{8}$ 48	$1\frac{7}{8}$ 48	$6\frac{3}{8}$ 162	$4\frac{7}{32}$ 107	3.594 91.3	1.252 31.8	2.343 59.5
75 3													
80 $3\frac{1}{4}$													
85 $3\frac{7}{16}$ $3\frac{1}{2}$ 95.2	$3\frac{3}{4}$ 95.2	13 330	$4\frac{1}{8}$ 105	10 254	$\frac{15}{16}$ 24	$1\frac{1}{2}$ 38	2 50.8	$2\frac{1}{4}$ 57	$7\frac{9}{16}$ 192	$4\frac{5}{8}$ 117.6	4.079 103.6	1.516 38.5	2.563 65.1
90 100 $3\frac{15}{16}$ 4 108	$4\frac{1}{4}$ 108	$15\frac{1}{4}$ 387	$4\frac{1}{2}$ 114	$12\frac{1}{2}$ 318	$\frac{15}{16}$ 24	$1\frac{17}{32}$ 39	$2\frac{1}{4}$ 57	$2\frac{7}{16}$ 62	$8\frac{3}{8}$ 213	$5\frac{3}{32}$ 129.6	4.484 113.9	1.626 41.3	2.858 72.6

XS4P

Cylindrical bore

(with set screw collar lock)

d 2 ⁷/₁₆ ~ 4 inch

60 ~ 100 mm

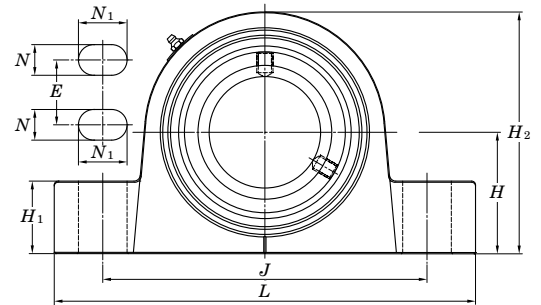
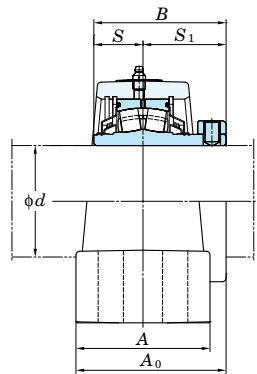

Unit No.	Bearing No.	Unit No.	Bearing No.	Housing No.	Bolt Size inch mm	Basic Load Ratings kN	
						C_r	C_{0r}
ZS4P412	ZS412	XS4P412	XS412	4P413	1/2 M12	173.3	220.4
ZS4P413-39	ZS413-39	XS4P413-39	XS413-39				
ZS4P413-40	ZS413-40	XS4P413-40	XS413-40				
ZS4P413	ZS413	XS4P413	XS413				
ZS4P414	ZS414	XS4P414	XS414	4P415	5/8 M16	186.8	244.4
ZS4P415-43	ZS415-43	XS4P415-43	XS415-43				
ZS4P415-44	ZS415-44	XS4P415-44	XS415-44				
ZS4P415-47	ZS415-47	XS4P415-47	XS415-47				
ZS4P415	ZS415	XS4P415	XS415				
ZS4P415-48	ZS415-48	XS4P415-48	XS415-48				
ZS4P416	ZS416	XS4P416	XS416	4P418	3/4 M20	284.1	383.7
ZS4P417-52	ZS417-52	XS4P417-52	XS417-52				
ZS4P417	ZS417	XS4P417	XS417				
ZS4P418-55	ZS418-55	XS4P418-55	XS418-55				
ZS4P418-56	ZS418-56	XS4P418-56	XS418-56				
ZS4P418	ZS418	XS4P418	XS418				
ZS4P420	ZS420	XS4P420	XS420	4P420	3/4 M20	364	497.2
ZS4P420-63	ZS420-63	XS4P420-63	XS420-63				
ZS4P420-64	ZS420-64	XS4P420-64	XS420-64				

4 - Bolt Base Pillow Block Units

ZDS4P

Cylindrical bore
(with Z Lock)

d $2 \frac{7}{16} \sim 4$ inch
60 ~ 100 mm

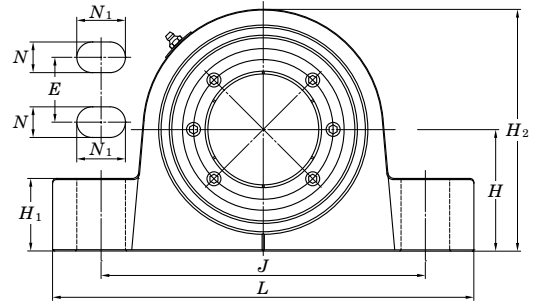
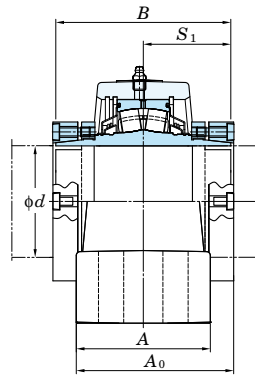

Shaft Dia. inch mm d	Dimensions inch mm											
	H	L	A	J	N	N_1	E	H_1	H_2	A_0	B	S_1
60 $2 \frac{7}{16}$ $2 \frac{1}{2}$	$2 \frac{3}{4}$ 69.8	$9 \frac{1}{4}$ 235	$3 \frac{3}{8}$ 86	$7 \frac{1}{8}$ 181	$\frac{19}{32}$ 15	$\frac{13}{16}$ 21	$1 \frac{3}{4}$ 44	$1 \frac{5}{8}$ 41	$5 \frac{19}{32}$ 142	$3 \frac{21}{32}$ 92.6	3.906 99.2	1.953 49.6
65 70 $2 \frac{11}{16}$ $2 \frac{3}{4}$ $2 \frac{15}{16}$	$3 \frac{1}{4}$ 82.6	$10 \frac{7}{16}$ 265	$3 \frac{3}{4}$ 95	$8 \frac{1}{8}$ 206	$\frac{25}{32}$ 20	$\frac{15}{16}$ 24	$1 \frac{7}{8}$ 48	$1 \frac{7}{8}$ 48	$6 \frac{3}{8}$ 162	$4 \frac{7}{32}$ 107	4.686 119	2.343 59.5
75 3												
80 $3 \frac{1}{4}$												
85 $3 \frac{7}{16}$ $3 \frac{1}{2}$	$3 \frac{3}{4}$ 95.2	13 330	$4 \frac{1}{8}$ 105	10 254	$\frac{15}{16}$ 24	$1 \frac{1}{2}$ 38	2 50.8	$2 \frac{1}{4}$ 57	$7 \frac{9}{16}$ 192	$4 \frac{5}{8}$ 117.6	5.126 130.2	2.563 65.1
90												
100 $3 \frac{15}{16}$ 4	$4 \frac{1}{4}$ 108	$15 \frac{1}{4}$ 387	$4 \frac{1}{2}$ 114	$12 \frac{1}{2}$ 318	$\frac{15}{16}$ 24	$1 \frac{17}{32}$ 39	$2 \frac{1}{4}$ 57	$2 \frac{7}{16}$ 62	$8 \frac{3}{8}$ 213	$5 \frac{3}{32}$ 129.6	5.716 145.2	2.858 72.6

XDS4P
Cylindrical bore
(with set screw collar lock)
 d 2 ⁷/₁₆ ~ 4 inch
 60 ~ 100 mm

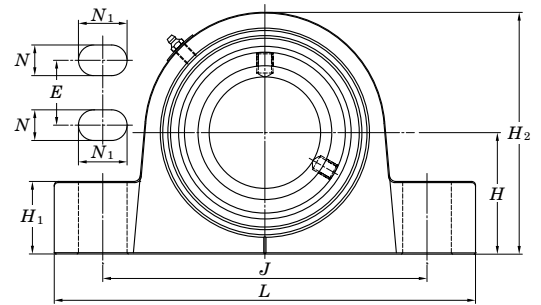
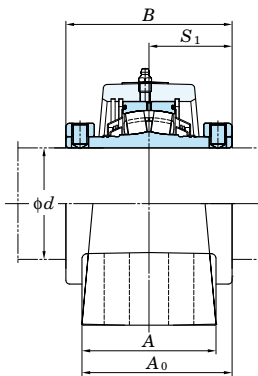
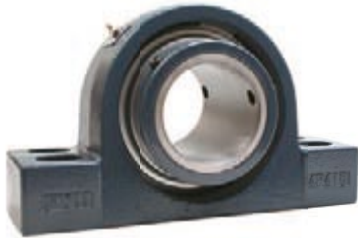

Unit No.	Bearing No.	Unit No.	Bearing No.	Housing No.	Bolt Size	Basic Load Ratings	
						inch	mm
ZDS4P412	ZDS412	XDS4P412	XDS412	4P413	1/2 M12	173.3	220.4
ZDS4P413-39	ZDS413-39	XDS4P413-39	XDS413-39				
ZDS4P413-40	ZDS413-40	XDS4P413-40	XDS413-40				
ZDS4P413	ZDS413	XDS4P413	XDS413	4P415	5/8 M16	186.8	244.4
ZDS4P414	ZDS414	XDS4P414	XDS414				
ZDS4P415-43	ZDS415-43	XDS4P415-43	XDS415-43				
ZDS4P415-44	ZDS415-44	XDS4P415-44	XDS415-44				
ZDS4P415-47	ZDS415-47	XDS4P415-47	XDS415-47				
ZDS4P415	ZDS415	XDS4P415	XDS415				
ZDS4P415-48	ZDS415-48	XDS4P415-48	XDS415-48				
ZDS4P416	ZDS416	XDS4P416	XDS416	4P418	3/4 M20	284.1	383.7
ZDS4P417-52	ZDS417-52	XDS4P417-52	XDS417-52				
ZDS4P417	ZDS417	XDS4P417	XDS417				
ZDS4P418-55	ZDS418-55	XDS4P418-55	XDS418-55				
ZDS4P418-56	ZDS418-56	XDS4P418-56	XDS418-56				
ZDS4P418	ZDS418	XDS4P418	XDS418	4P420	3/4 M20	364	497.2
ZDS4P420	ZDS420	XDS4P420	XDS420				
ZDS4P420-63	ZDS420-63	XDS4P420-63	XDS420-63				
ZDS4P420-64	ZDS420-64	XDS4P420-64	XDS420-64				

Spherical Roller Bearing Inserts

ZS4
Cylindrical bore
(with Z Lock)
d 1 3/8 ~ 4 inch
 40 ~ 100 mm

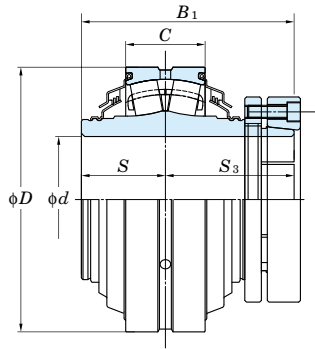

XS4
Cylindrical bore
(with set screw collar lock)

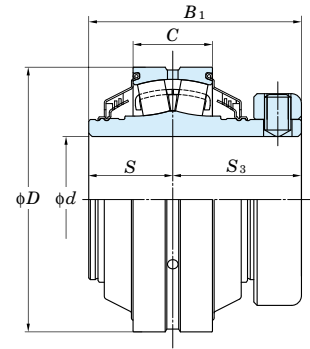

Shaft Dia. inch mm <i>d</i>	Dimensions inch mm					Bearing No.	Bearing No.	Basic Load Ratings kN	
	<i>C</i>	<i>D</i>	<i>B</i> ₁	<i>S</i>	<i>S</i> ₃			<i>C</i> _r	<i>C</i> _{0r}
1 3/8 1 7/16 1 1/2 40	15/16 24	3 5/32 80	2.531 64.3	1 25.4	1.531 38.9	ZS408-22 ZS408-23 ZS408-24 ZS408	XS408-22 XS408-23 XS408-24 XS408	88.7	101.1
1 11/16 1 3/4 45	15/16 24	3 11/32 85	2.657 67.5	1 25.4	1.657 42.1	ZS409-27 ZS409-28 ZS409	XS409-27 XS409-28 XS409	92.6	108.8
1 15/16 50 2	15/16 24	3 17/32 90	2.843 72.2	1 25.4	1.843 46.8	ZS410-31 ZS410 ZS410-32	XS410-31 XS410 XS410-32	96.4	116.9
55 2 3/16 2 1/4	1 1/32 26	3 15/16 100	2.937 74.6	1.126 28.6	1.811 46	ZS411 ZS411-35 ZS411-36	XS411 XS411-35 XS411-36	120.8	146.8
60 2 7/16 2 1/2	1 1/4 32	4 23/32 120	3.205 81.4	1.252 31.8	1.953 49.6	ZS412 ZS413-39 ZS413-40 ZS413	XS412 XS413-39 XS413-40 XS413	173.3	220.4
70 2 11/16 2 3/4 2 15/16 75 3	1 1/4 32	5 1/8 130	3.594 91.3	1.252 31.8	2.343 59.5	ZS414 ZS415-43 ZS415-44 ZS415-47 ZS415 ZS415-48	XS414 XS415-43 XS415-44 XS415-47 XS415 XS415-48	186.8	244.4
80 3 1/4 85 3 7/16 3 1/2 90	1 5/8 41	6 5/16 160	4.079 103.6	1.516 38.5	2.563 65.1	ZS416 ZS417-52 ZS417 ZS418-55 ZS418-56 ZS418	XS416 XS417-52 XS417 XS418-55 XS418-56 XS418	284.1	383.7
100 3 15/16 4	1 27/32 47	7 3/32 180	4.484 113.9	1.626 41.3	2.858 72.6	ZS420 ZS420-63 ZS420-64	XS420 XS420-63 XS420-64	364	497.2

ZDS4
Cylindrical bore
(with Z Lock (both))
d 2 ⁷/₁₆ ~ 4 inch
 60 ~ 100 mm

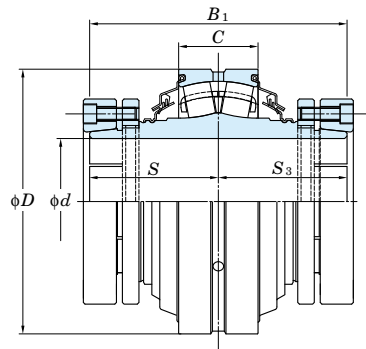

XDS4
Cylindrical bore
(with set screw collar lock (both))

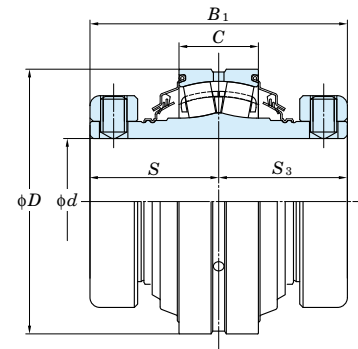

Shaft Dia. inch mm <i>d</i>	Dimensions inch mm					Bearing No.	Bearing No.	Basic Load Ratings kN	
	<i>C</i>	<i>D</i>	<i>B</i> ₁	<i>S</i>	<i>S</i> ₃			<i>C</i> _r	<i>C</i> _{0r}
60 2 ⁷ / ₁₆ 2 ¹ / ₂	1 ¹ / ₄ 32	4 ²³ / ₃₂ 120	3.905 99.2	1.953 49.6	1.953 49.6	ZDS412 ZDS413-39 ZDS413-40 ZDS413	XDS412 XDS413-39 XDS413-40 XDS413	173.3	220.4
65 70 2 ¹¹ / ₁₆ 2 ³ / ₄ 2 ¹⁵ / ₁₆	1 ¹ / ₄ 32	5 ¹ / ₈ 130	4.685 119	2.343 59.5	2.343 59.5	ZDS414 ZDS415-43 ZDS415-44 ZDS415-47 ZDS415	XDS414 XDS415-43 XDS415-44 XDS415-47 XDS415	186.8	244.4
75 3 80 3 ¹ / ₄	1 ⁵ / ₈ 41	6 ⁵ / ₁₆ 160	5.126 130.2	2.563 65.1	2.563 65.1	ZDS416 ZDS417-52 ZDS417 ZDS418-55 ZDS418-56 ZDS418	XDS416 XDS417-52 XDS417 XDS418-55 XDS418-56 XDS418	284.1	383.7
85 3 ⁷ / ₁₆ 3 ¹ / ₂	1 ²⁷ / ₃₂ 47	7 ³ / ₃₂ 180	5.716 145.2	2.858 72.6	2.858 72.6	ZDS420 ZDS420-63 ZDS420-64	XDS420 XDS420-63 XDS420-64	364	497.2
90 3 ¹⁵ / ₁₆ 4									

PRECAUTIONS

- Read the entire installation guide prior to beginning.
- Bearings are precision instruments and they must always be handled carefully to prevent damage.
- Store bearings in a cool and dry location, and always leave bearings in original packaging until ready for installation.
- Bearing life calculations should be performed prior to installation to ensure that the selected unit is acceptable for the application.
- The use of more than two bearings on a single shaft is not recommended.
- To maximize the life of the bearing avoid mis-alignment and pre-loading by carefully following these instructions.
- Always lock out the power source and adhere closely to industry safety standards before performing any work on the equipment.

PREPARATION

The mounting surface and housing base must be clean, flat, and of sufficient thickness to support the weight of the entire assembly without deflecting or breaking. Make sure that the mounting surface is parallel to the plane of the shaft for pillow blocks, and perpendicular to the shaft for flanges and take-up units. FYH mounted bearings can accommodate up to ±2 degrees of mis-alignment, however longer bearing life can be achieved if mis-alignment can be minimized during installation.

Check the shaft diameter and make sure that it is within tolerance as indicated in **Table 1**. Check that the shaft is straight, clean, and free of burrs or other imperfections. Use emery cloth or a fine file to smooth the surface as necessary. A small amount of lubricant may be applied to both the shaft and the bore of the bearing; however lubricant should not be applied to the areas where the bearing locking mechanism contacts the shaft.

Shaft Size (mm)		h6		h7	
		Shaft Speed Greater Than 50% of Max RPM Rating		Shaft Speed Less Than 50% of Max RPM Rating	
Over	Incl.	Max (mm)	Min (mm)	Max (mm)	Min (mm)
30	50	0	-0.016	0	-0.025
50	80	0	-0.019	0	-0.03
80	120	0	-0.022	0	-0.035

INSTALLATION

1. Slide the unit onto the shaft while holding the inner ring of the bearing. Position the unit on the mounting surface so that the plane of the shaft is perpendicular to the face of the housing, and alternately tighten the mounting bolts to the specified torque as shown in **Table 2**. Make sure to use bolts, washers, and nuts of sufficient strength and grade rating for the application.

Bolt Size		Tightening Torque		
mm	inch	N·m	in-lbf	ft-lbf
M6	1/4	5	43	4
M8	5/16	10	92	8
M10	3/8	22	196	17
M12	7/16	38	334	27
M14	1/2	61	541	46
M16	5/8	95	840	70
M18	—	139	1231	103
M20	3/4	189	1664	139
M22	7/8	260	2301	192
M27	1	484	4277	358

2. Check the final position of the shaft and alternately tighten the set screws of the non-expansion unit onto the shaft to the specified torque setting as shown in **Table 3**. The set screws in the bearing on the opposite side of the shaft should line up with the set screws of the bearing that was installed first (**See Table 4, Figure A**). Expansion bearings should be installed only after the shaft and adjacent machinery has cooled down to the ambient temperature. After positioning the expansion unit on the shaft slide the insert to the rearmost position within the housing until it seats against the retaining ring. Then slide the insert forward in the housing approximately one thirty-second of an inch (1/32") and alternately tighten the set screws onto the shaft to the specified torque setting as shown in **Table 3**. Allowable shaft expansion and expansion calculation data can be found in **Table 4** and **Formula 1** respectively.

Size Code	Set Screw Size	Set Screw Tightening Torque		
		N-m	in-lbf	ft-lbf
XS408-XS409	5/16-28UNF×1/2	14.5	128	11
XS410-XS413	3/8-24UNF×5/8	25.5	226	19
XS414-XS420	1/2-20UNF×3/4	56.5	500	42

Size Code		Quantity of Total Movement	
		mm	inch
XS408-XS410	ZS408-ZS410	5	13/64
XS411-XS420	ZS411-ZS420	6	15/64

Formula 1 – Linear Shaft Expansion	Figure A – Set Screws Lined Up in Both Bearings
$L = A \cdot T \cdot D$ <p>L : Expansion of shaft (mm) A : Linear expansion coefficient of shaft for ordinary steel (11.5×10^{-6}) T : Temperature increase (°C) D : Installation distance between bearing units (mm)</p> <p>Allowable shaft expansion: 3/16" max</p>	

3. Once installed, slowly rotate the bearing by hand to confirm that it turns smoothly and without resistance, vibration, or any other abnormalities.

4. To install **Z LOCK**, tighten the four cap screws on the face of the locking collar with the included Allen wrench evenly. Repeat to draw the collar onto the inner ring. (**See Table 5**) To disassemble, remove all the black cap screws as well as the two silver cap screws. Screw two black cap screws where the silver cap screws had been. Screw the two black cap screws until the collar disengages.

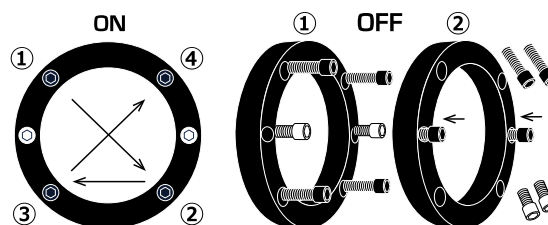

Size Code	Allen Wrench (mm)	Tightening Torque		
		N-m	in-lbf	ft-lbf
ZS408-ZS409	3	0.6-1.1	5-10	0.5-0.8
ZS410-ZS411	4	1.2-2.2	10-19	0.9-1.7
ZS412-ZS420	5	2.4-4.4	21-39	1.8-3.3

LUBRICATION

Proper lubrication practices will greatly extend the life of the bearing.

Bearings are factory lubricated with the proper amount and type of lubricant for most general purpose applications as well as many highly demanding operating environments, and except as recommended by FYH, no further lubrication is required upon installation.

Lubrication tips:

- The factory standard lubricant is a **calcium sulfonate** grease. Always use the same type of lubricant to avoid compatibility issues and other potential problems.
- When adding lubricant do so slowly and while the bearing is rotating until a small amount of lubricant can be seen coming out of the seals.
- At low speeds (below 200 RPM) it is acceptable to completely fill the bearing with grease.
- At moderate to high speeds it is not advisable to completely fill the bearing with grease as it could lead to overheating and reduced bearing life.
- It is generally better to use less lubrication more frequently than more lubricant less often.
- If the unit will not be operated for an extended period of time extra lubricant should be added to prevent corrosion.
- If the unit has not been operated for an extended period of time fresh lubricant should be added prior to start-up.
- If the unit becomes too hot during operation from over-lubrication remove the grease fitting and operate the unit for approximately thirty minutes to allow excess grease to purge.

Appropriate lubrication intervals can be determined by referring to **Table 6**; however experience should largely determine the actual lubrication regimen for a particular application. Consult with an FYH representative for assistance.

If a suitable Calcium Sulfonate lubricant is not available for re-lubrication then the following compatible lubricants may also be used:

Barium Complex, Calcium Stearate, Lithium Complex, Polyurea (Shear Stable)

The use of any other type of lubricant should be avoided to prevent compatibility issues with the Calcium Sulfonate grease that is originally supplied.

To find the proper lubrication interval in **Table 6** obtain the relevant percentage of max allowable RPM by referring to **Table 7**.

Example: XS411 with positive contact seals has a max RPM rating of 2000. If the application has an RPM of 600 then the percentage of max RPM is 30% ($600/2000 = .30$).

The amount of grease for replenishment can be found in **Table 8**.

Table 6 - Lubrication Schedule (recommended)								
Environment	Clean to Moderately Dirty							Dirty to Very Dirty
Temperature (°C)	Under 120 degrees				Over 120 degrees			From -20 to 200
% of max allowable RPM	0 - 25%	25 - 50%	50 - 75%	75 - 100%	0 - 25%	25 - 50%	50 - 100%	0 - 100%
Lubrication interval	From three to eight months	From one to three months	From one week to one month	Daily to once per week	From two to six weeks	From one week to one month	Daily to once per week	Daily to once per week

Table 7 - Limiting Speed for Seals (min ⁻¹)			
Size Code		Standard Triple Lip Seal Limiting	Non Contact Seal Limiting
XS408	ZS408	2750	3200
XS409	ZS409	2450	2800
XS410	ZS410	2200	2600
XS411	ZS411	2000	2360
XS412-XS413	ZS412-ZS413	1692	2000
XS414-XS415	ZS414-ZS415	1460	1730
XS416-XS418	ZS416-ZS418	1220	1440
XS420	ZS420	1100	1300

Table 8 - Grease Amount for Replenishment (recommended)		
Size Code		Amount of Grease (grams)
XS408	ZS408	7-8
XS409	ZS409	7-9
XS410	ZS410	8-9
XS411	ZS411	10-12
XS412-XS413	ZS412-ZS413	19-22
XS414-XS415	ZS414-ZS415	22-26
XS416-XS418	ZS416-ZS418	40-46
XS420	ZS420	50-59

Converting units from fixed to expansion

FYH mounted roller units are capable of operating in both a fixed or expansion configuration.

Before bearing installation

On the back side of the unit (opposite the housing markings), remove the bearing retaining ring located on the inner diameter of the housing and move it back to the groove on the outer position of the housing. Slide the bearing insert rearward within the housing until it sits against the retaining ring that was just relocated. When ready for installation, slide the insert forward in the housing approximately one thirty-second of an inch ($1/32''$) and alternately tighten the set screws onto the shaft to the specified torque setting as shown in **Table 3**.

After bearing installation

Before performing any work on the bearing, lock out the power source and allow the shaft and adjacent machinery to cool down to ambient temperature. Loosen the set screws or other locking mechanism to allow the shaft to move freely within the bore then follow the same procedures explained in the **"Before bearing installation"** section.

Allowable Radial Load (kN) at Various RPM																				
Shaft Size	Size	L _{10h}	RPM																	
			50	100	150	300	500	750	1000	1200	1400	1600	1800	2000	2200	2400	2600	2800	3000	3200
1 3/8" 1 7/16" 1 1/2" 40 mm	XS408 ZS408	10000	31.9	25.9	23	18.6	16	14.1	13	12.3	11.7	11.3	10.9	10.5	10.2	10	9.7	9.5	9.3	9.1
		25000	24.2	19.7	17.4	14.1	12.1	10.7	9.8	9.3	8.9	8.5	8.2	8	7.8	7.6	7.4	7.2	7.1	6.9
		50000	19.7	16	14.1	11.5	9.8	8.7	8	7.6	7.2	6.9	6.7	6.5	6.3	6.1	6	5.9	5.7	5.6
		70000	17.8	14.4	12.8	10.4	8.9	7.9	7.2	6.8	6.5	6.3	6	5.9	5.7	5.5	5.4	5.3	5.2	5.1
		100000	16	13	11.5	9.3	8	7.1	6.5	6.1	5.9	5.6	5.4	5.3	5.1	5	4.9	4.7	4.6	4.6
1 11/16" 1 3/4" 45 mm	XS409 ZS409	10000	33.3	27.1	24	19.5	16.7	14.8	13.5	12.8	12.2	11.8	11.3	11	10.7	10.4	10.2	9.9		
		25000	25.3	20.6	18.2	14.8	12.7	11.2	10.3	9.7	9.3	8.9	8.6	8.3	8.1	7.9	7.7	7.5		
		50000	20.6	16.7	14.8	12	10.3	9.1	8.3	7.9	7.5	7.2	7	6.8	6.6	6.4	6.2	6.1		
		70000	18.6	15.1	13.4	10.8	9.3	8.2	7.5	7.1	6.8	6.5	6.3	6.1	5.9	5.8	5.6	5.5		
		100000	16.7	13.5	12	9.7	8.3	7.4	6.8	6.4	6.1	5.9	5.7	5.5	5.3	5.2	5.1	5		
1 15/16" 50 mm 2"	XS410 ZS410	10000	34.7	28.2	24.9	20.2	17.4	15.4	14.1	13.3	12.7	12.1	11.8	11.4	11.1	10.8	10.6			
		25000	26.3	21.4	18.9	15.4	13.2	11.7	10.7	10.1	9.7	9.3	9	8.7	8.4	8.2	8			
		50000	21.4	17.4	15.4	12.5	10.7	9.5	8.7	8.2	7.8	7.5	7.3	7	6.8	6.7	6.5			
		70000	19.3	15.7	13.9	11.3	9.7	8.6	7.8	7.4	7.1	6.8	6.6	6.4	6.2	6	5.9			
		100000	17.4	14.1	12.5	10.1	8.7	7.7	7	6.7	6.4	6.1	5.9	5.7	5.5	5.4	5.3			
55 mm 2 3/16" 2 1/4"	XS411 ZS411	10000	43.5	35.3	31.3	25.4	21.8	19.3	17.7	16.7	16	15.4	14.8	14.4	14					
		25000	33	26.8	23.8	19.3	16.5	14.6	13.4	12.7	12.1	11.7	11.2	10.9	10.6					
		50000	26.8	21.8	19.3	15.7	13.4	11.9	10.9	10.3	9.8	9.5	9.1	8.8	8.6					
		70000	24.3	19.7	17.4	14.1	12.1	10.7	9.8	9.3	8.9	8.5	8.2	8	7.8					
		100000	21.8	17.7	15.7	12.7	10.9	9.6	8.8	8.4	8	7.7	7.4	7.2	7					
60 mm 2 7/16" 2 1/2" 65 mm	XS412 XS413 ZS412 ZS413	10000	62.4	50.7	44.9	36.5	31.3	27.7	25.4	24	23	22	21.3	20.6						
		25000	47.4	38.5	34.1	27.7	23.7	21	19.3	18.3	17.4	16.7	16.2	15.7						
		50000	38.5	31.3	27.7	22.5	19.3	17.1	15.6	14.8	14.1	13.6	13.1	12.7						
		70000	34.8	28.3	25	20.3	17.4	15.4	14.1	13.4	12.8	12.3	11.9	11.5						
		100000	31.3	25.4	22.5	18.2	15.6	13.9	12.7	12	11.5	11	10.6	10.3						
70 mm 2 11/16" 2 3/4" 2 15/16" 75 mm 3"	XS414 XS415 ZS414 ZS415	10000	67.3	54.6	48.4	39.3	33.7	29.8	27.4	25.9	24.7	23.8								
		25000	51.1	41.5	36.7	29.8	25.6	22.7	20.8	19.7	18.8	18								
		50000	41.5	33.7	29.8	24.2	20.8	18.4	16.9	16	15.2	14.6								
		70000	37.5	30.5	27	21.9	18.8	16.6	15.2	14.4	13.8	13.2								
		100000	33.7	27.4	24.2	19.7	16.9	14.9	13.7	13	12.4	11.9								
80 mm 3 1/4" 85 mm 3 7/16" 3 1/2" 90 mm	XS416 XS417 XS418 ZS416 ZS417 ZS418	10000	102.4	83.1	73.6	59.8	51.3	45.4	41.6	39.4	37.6									
		25000	77.7	63.1	55.9	45.4	38.9	34.5	31.6	29.9	28.6									
		50000	63.1	51.3	45.4	36.9	31.6	28	25.7	24.3	23.2									
		70000	57.1	46.3	41	33.3	28.6	25.3	23.2	22	21									
		100000	51.3	41.6	36.9	29.9	25.7	22.7	20.8	19.7	18.8									
100 mm 3 15/16" 4"	XS420 ZS420	10000	131.2	106.5	94.3	76.6	65.7	58.2	53.4	50.5	48.2									
		25000	99.6	80.9	71.6	58.2	49.9	44.2	40.5	38.4	36.6									
		50000	80.9	65.7	58.2	47.3	40.5	35.9	32.9	31.2	29.7									
		70000	73.1	59.4	52.6	42.7	36.6	32.4	29.7	28.2	26.9									
		100000	65.7	53.4	47.3	38.4	32.9	29.1	26.7	25.3	24.2									

1. Blue area: The Standard Triple Lip Seal is used.

2. Green area: A non-contact seal is used.



FYH®

Findling Wälzlager GmbH

ABEG® Deutschland
Schoemperlenstr. 12
76185 Karlsruhe

Tel +49 (721) 55 999-0
Fax +49 (721) 55 999-140

info@findling.com
www.findling.com